



# STAR VARIO PRODUCT CATALOGUE

The Expert in Lubrication Solutions

**perma**

# CONTENT

<b>Benefits of Lubrication</b>	<b>4-9</b>
Bearing Life Extension	4
Contamination Prevention	6
Workplace Safety Improvements	8
Industrial Digitalisation	10
<b>Product Overview</b>	<b>12-25</b>
perma STAR VARIO	12
perma STAR CONTROL	14
<b>perma CONNECT</b>	<b>16-17</b>
perma STAR VARIO LONG RANGE	18
perma STAR VARIO BLUETOOTH	20
<b>Dispensing Rates</b>	<b>22-23</b>
<b>Lubricator Operational Status</b>	<b>24-25</b>
<b>perma Installation Kits</b>	<b>26-39</b>
perma STAR VARIO Installation Kits - Overview	26
Standard Duty Kits 60, 120 and 250 cm <sup>3</sup>	28
Heavy Duty Kits 60, 120 and 250 cm <sup>3</sup>	30
Manifold Kits	32
Direct Mount and Rail Kits	34
Standard Duty Kits 500 cm <sup>3</sup>	36
Heavy Duty Kits 500 cm <sup>3</sup>	38
<b>Remote Installation Guidelines</b>	<b>40-41</b>
<b>Common Equipment and Applications</b>	<b>42-49</b>
Slurry Pumps	42
Conveyor Pulley Bearings	44
Electric Motors	46
Fans	48
<b>Accessories</b>	<b>50-53</b>
<b>Fittings Cases</b>	<b>54-57</b>
<b>Inspection Guidelines</b>	<b>58</b>
<b>Service Guidelines</b>	<b>59</b>
<b>Lubricants</b>	<b>60-61</b>



## The Expert in Lubrication Solutions

### **perma-tec GmbH & Co. KG (Germany)**

Inventing and patenting the perma CLASSIC single point lubricator in 1964, perma-tec GmbH & Co. KG is the global leader in the research, development and manufacturing of automatic lubricators. perma lubrication systems can be found in all types of industries and applications around the world. perma lubrication systems are manufactured in Germany in state-of-the-art facilities.

### **HTL perma Australia Pty Ltd**

As a subsidiary of perma-tec GmbH & Co. KG, HTL perma Australia Pty Ltd has direct access to the Research & Development Centre and Engineering Group in Germany.

HTL perma Australia Pty Ltd responds to the demands of preventative maintenance programs by focusing on service, customised solutions and knowledge sharing. We understand that our products deliver maximum value when combined with robust installation systems, a practical approach to maintenance scheduling and ongoing technical support.

The information provided in this document is of a general nature only. Potential users of perma Automatic Lubricators should seek advice tailored to their particular circumstances and, for this purpose, are welcome to contact HTL perma Australia Pty Ltd on the contact number provided. HTL perma Australia Pty Ltd is not liable for any costs, losses or damages, whether direct or indirect, arising from any reliance upon this document. Details relating to product designs and specifications may be to subject change without prior notice.

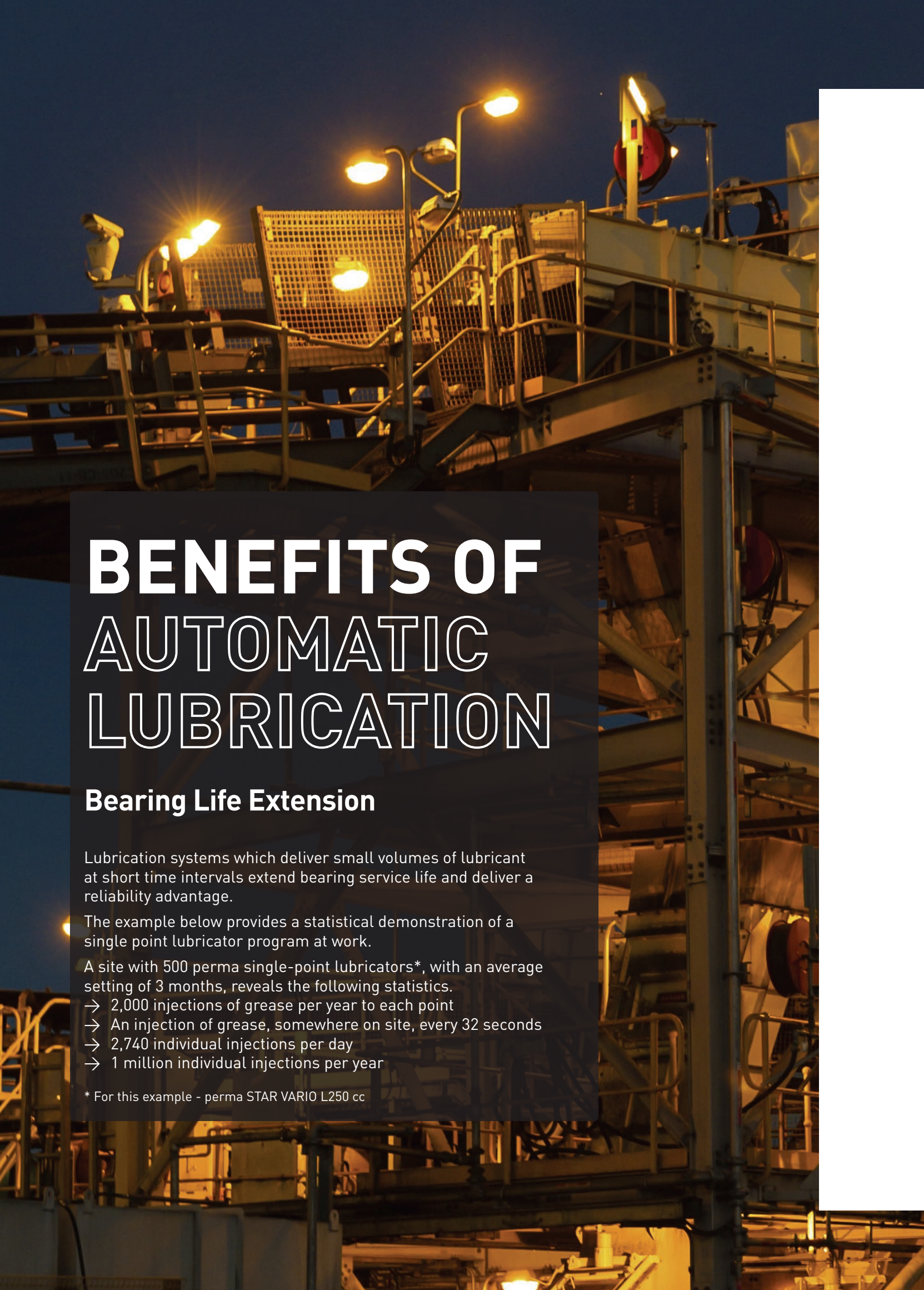

# BENEFITS OF AUTOMATIC LUBRICATION

## Bearing Life Extension

Lubrication systems which deliver small volumes of lubricant at short time intervals extend bearing service life and deliver a reliability advantage.

The example below provides a statistical demonstration of a single point lubricator program at work.

A site with 500 perma single-point lubricators\*, with an average setting of 3 months, reveals the following statistics.

- 2,000 injections of grease per year to each point
- An injection of grease, somewhere on site, every 32 seconds
- 2,740 individual injections per day
- 1 million individual injections per year

\* For this example - perma STAR VARIO L250 cc

## THE COST OF WEAR

To be competitive, manufacturing, mineral processing and mining operations must maximise production output while minimising long term operating costs. Key to achieving this is the implementation of preventative maintenance strategies which extend equipment service life and minimise downtime required for maintenance, repair and overhaul.

Fundamentally, reducing wear reduces the total cost of ownership of production assets and improves business performance.

Reducing wear also delivers a sustainability benefit, because when equipment and machinery lasts longer, without the need for repair or replacement, energy and material consumption is reduced.

Cost and downtime due to premature wear is significant. Good lubrication strategies have a dramatic effect on extending bearing service life and therefore reducing costs and improving equipment reliability. The chart shown provides estimates of the causes of premature bearing failures. Poor lubrication practices and contamination are the major causes.

Industry leading businesses invest in automatic lubrication systems for the purpose of bearing relubrication and contaminant exclusion because they deliver superior reliability results compared to manual lubrication.

New product developments which focus on connectivity and digitalisation add further value to the maintenance and reliability effort, by providing options to optimise lubrication management via remote monitoring, remote control and desktop auditing.

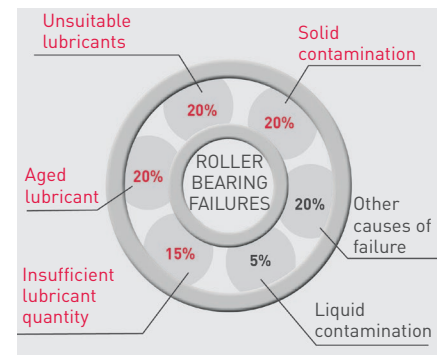

## BENEFITS OF SHORT LUBRICATION INTERVALS

Bearing lubrication must maintain fresh grease around the working components of bearings. Lubricant starvation leads to the deterioration of lubrication conditions and premature wear. For high-speed bearings, the rapid supply of large amounts of grease can cause over-lubrication which leads to rapid lubricant degradation and in severe cases may result in bearing failure.

The longest bearing service life is achieved when grease is added in small amounts at short time intervals. This regime of grease delivery maintains a steady state of lubrication protection where over-lubrication and lubricant starvation do not occur.

Factors which reduce the service life of the grease include high speeds, elevated temperatures, vibration and high loads. When operating conditions like these prevail, the benefits of delivering small amounts of grease at short time intervals are at their greatest.

The diagram shown demonstrates the advantage of lubrication methods which deliver small amounts of grease at short time intervals.

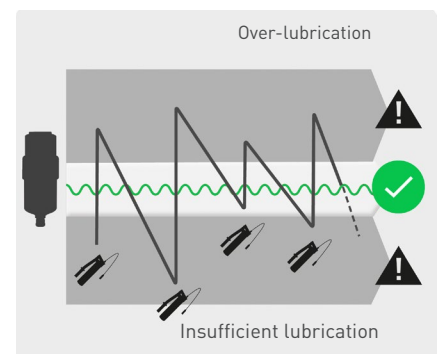

### Too much grease

- Elevated operating temperature and rapid degradation of grease for high speed bearings
- Less efficient use of fresh grease
- Potential to damage contact type seals

### Too little grease

- Starvation causing premature wear
- Accelerated degradation of grease
- Increased risk for contamination entry



# BENEFITS OF AUTOMATIC LUBRICATION

## Contamination Prevention

The contamination of bearings by water and solid particles causes accelerated wear and dramatically reduces bearing service life. Industries which involve the handling of abrasive material suffer the greatest losses as a result of inadequate contamination control procedures and systems.

perma automatic lubricators provide a consistent and regular purge of clean grease through bearing seals to prevent the entry of water, dirt and dust, and in doing so, extend bearing service life.

Advancement of connected solutions, where automatic lubricators are monitored and controlled via wireless communication provide new opportunities to dramatically improve workplace safety.

## PREVENTING CONTAMINATION IN HARSH OPERATING ENVIRONMENTS

When solid or liquid contaminants enter a bearing, they cause accelerated wear and the early onset of fatigue. For solid contaminants the rate of wear increases with the size, concentration, and hardness of contaminants. Smaller particles lead to abrasive wear whilst larger particles can cause indentation of bearing raceways and rolling elements which become sites of fatigue related wear. Lubrication practices which prevent the ingress of contaminants provide long term financial return by means of longer bearing service life and reduced downtime.

Strategies for preventing contamination vary depending on bearing housing and seal configurations. For bearings with free-purging labyrinth or taconite seals, contamination prevention is achieved by delivering a consistent purge of clean grease through the seals. In simple terms, if clean grease is purging out of the seal, contaminants, whether they be solid or liquid, are prevented from entering.

Bearings which operate in harsh environments, including high humidity and high levels of liquid or solid contaminants, demand the strictest attention to regular seal purging. Under such conditions automatic purging of seals provides the greatest benefits.

## CONTAMINANT PREVENTION STRATEGIES

### Slurry pump seal purging

Automatic purging of labyrinth seals provides constant protection against ingress of solids and liquids. For pumps where the wet-end seal is subjected to direct water spray, a higher rate of automatic purging is applied to compensate for the elevated rate of grease washout.

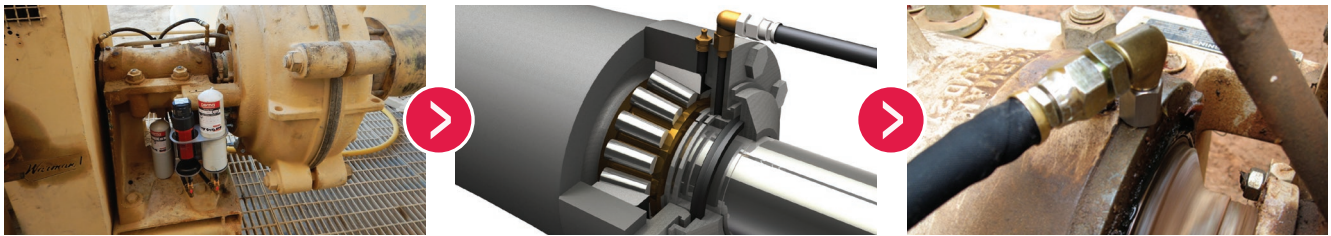

### Conveyor pulley bearing relubrication & seal purging

Automatic purging of taconite or labyrinth type seals provides constant protection against the ingress of contaminants. For the example shown, bearing relubrication is provided by a separate automatic lubricator.

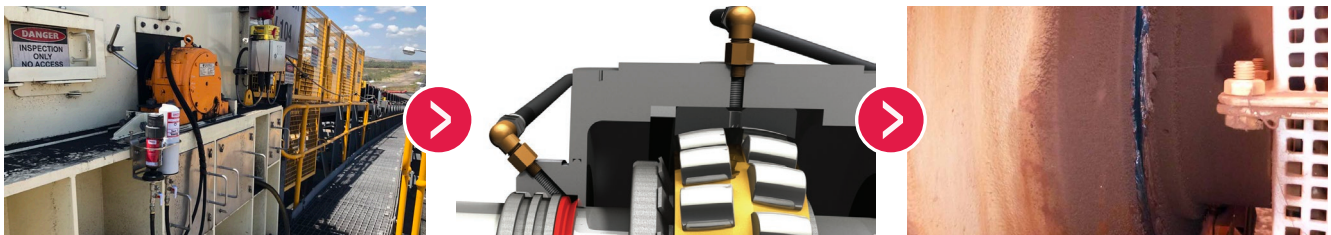

### Conveyor pulley bearing seal purging (hybrid solution)

Automatic purging of taconite or labyrinth type seals provides constant protection against the ingress of contaminants. For this solution, bearing relubrication is provided manually. This hybrid system can provide a practical balance between automatic and manual greasing for large pulley bearings.

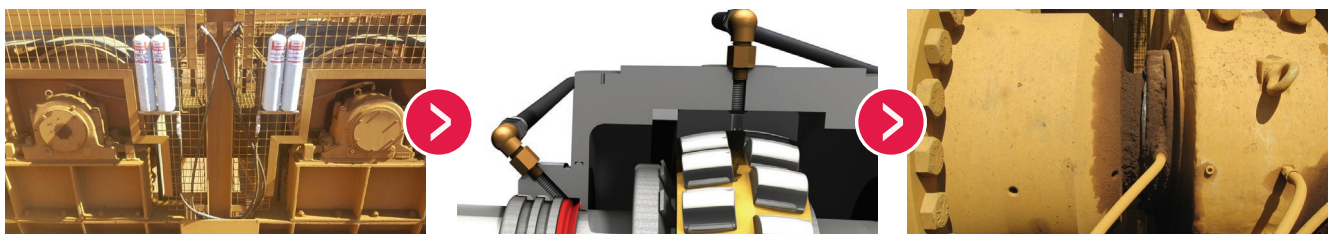



# BENEFITS OF AUTOMATIC LUBRICATION

## Workplace Safety Improvements

Workplace safety is of the highest importance. Reliable systems which reduce the interface between people and operating equipment are a key element to eliminating workplace accidents.

Advancements of connected solutions, where automatic lubricators are monitored and controlled via wireless communication, provide new opportunities to dramatically improve workplace safety.

## STRATEGIES TO IMPROVE SAFETY AND EFFICIENCY

Automatic lubrication systems are maintenance tools which make a positive contribution to workplace safety and efficiency. This is particularly relevant for large operations in hot climates where the physical demands of performing regular manual greasing increases the risk of fatigue and heat exhaustion compared to automatic alternatives.

New products, such as the perma STAR VARIO LONG RANGE, deliver a step change to lubrication related safety via online lubricator monitoring and control; improving safety by minimising worker exposure to airborne dusts, noise and uv radiation.

The implementation of automatic lubrication systems does not mean that general equipment inspections should be neglected. Implementation of automatic lubrication systems can lead to time savings, which can then be invested into other critical maintenance tasks, such as general inspections, condition monitoring data collection, oil sampling and oil cleanliness management activities such as filtration and clarification.

## STRATEGIES TO IMPROVE SAFETY AND EFFICIENCY

**Strategy 1** – Remote mount lubricators for large electric motors, fans and pumps at safe and easy to reach locations.

**Safety** – Improve safety via the remote installation of lubricators at safe to access locations.

**Efficiency** – Save time which would otherwise be required to locate and use safety steps.

Example - Direct mounting of lubricators to the fan bearings shown would require personnel to climb onto the fan structure or use a safety step for lubricator inspection and servicing. The remote mounting solution allows lubricators to be safely handled from ground level.



**Strategy 2** – Monitor and control lubricators remotely via smart device App and the internet.

**Safety** – Improve safety by reducing the requirement to conduct periodic inspections and via remote monitoring of lubricators which are difficult to access.

**Efficiency** – Save time which would otherwise be required for routine inspections or to gain safe access to lubricators in difficult to access locations.

Example - The perma STAR VARIO LONG RANGE lubrication systems shown are deployed on the conveyor circuit of a large mining operation.



**Strategy 3** – Bluetooth enabled lubricators to lubricate conveyor pulley bearings on a shuttle/tripper which are located behind safety cages.

**Safety** – Improve safety by remote monitoring lubricators with the CONNECT App.

**Efficiency** – Save time required during shuts for permits, isolations and cage removal to inspect lubricators.

Example - The perma STAR VARIO BLUETOOTH lubricators shown are delivering grease to the bearing relubrication point and seal purge point of a conveyor pulley bearing.



# BENEFITS OF AUTOMATIC LUBRICATION

## Industrial Digitalisation

As the popularity of connected automatic lubrication systems grows, the significance of their contribution to the broader topic of digitalisation of reliability programs is being proven.

Connected lubrication systems provide complete transparency of lubrication programs – lubrication system operational status, lubricant delivery rates and upcoming service requirements are displayed on a simple and intuitive dashboard.

Vital lubrication data which has previously not been available, allows reliability professionals to optimise lubrication programs, by facilitating meaningful desktop reviews and forensic investigations.



## LUBRICATION PROGRAM RISK MITIGATION

- > Remote monitoring and control of automatic lubrication systems delivers a step change in reducing reliability risk.
- > Lubrication systems which have stopped are identified on the easy-to-read dashboards which can be viewed via desktop Web App or in the field on a smart device.
- > Dashboard information includes the date and time when lubrication systems stopped, and why it stopped.
- > Monitoring motor current of the lubrication systems allows advanced warnings of potential problems with severed grease lines or the emergence of grease flow blockages.

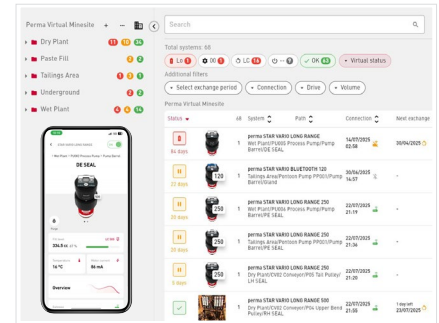

## WORK EFFICIENCY GAINS

- > If condition monitoring sensors indicate the emergence of lubricant starvation, the lubrication system dashboard becomes the first line of defense, with options to send extra grease purges or to adjust lubrication rates.
- > Online monitoring of lubrication systems does not mean that general inspections can be eliminated, but they can often be reduced, saving time and improving workplace safety.
- > If system problems are shown on the dashboard, lubrication technicians can plan to visit the effected assets, pre-informed of what they can expect to find, meaning that the right tools and parts can be prepared to complete rectification work efficiently.
- > Multi-device commands allow all or any section of the lubrication program to be stopped and started, providing significant efficiencies during extended shuts.



## THE POWER OF DATA

- > Root cause failure analysis can be conducted supported by lubrication history data and charts.
- > Desktop audits and resulting system adjustments allow the overall lubrication program to be optimised and efficiently managed.
- > Where companies embrace the digitalisation of lubrication systems across multiple operations, cross-site benchmarking and the identification of best practice lubrication strategies become a reality.

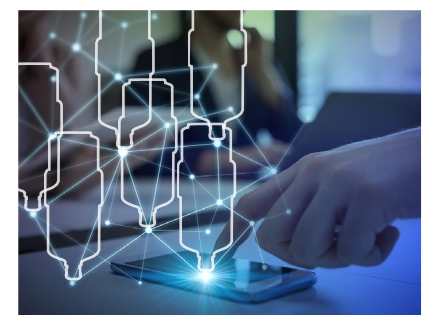



## perma STAR VARIO

Electro-mechanical, weekly and monthly time settings and four cartridge sizes

perma STAR VARIO consists of a reusable electro-mechanical drive unit and a single-use lubricant cartridge. Because the lubricator is mechanically driven the dispensing rate is independent of ambient temperature and back pressure<sup>†</sup>.

Inspection of the perma STAR VARIO is made easy via the combination of the transparent lubricant cartridge, a flashing LED alert system and an LCD display screen which communicates the status of the lubricator to maintenance personnel.

<sup>†</sup>Total resistance to grease flow must be less than the pressure delivery capability of the lubricator.

More information can be found on our website [www.perma.com.au](http://www.perma.com.au)

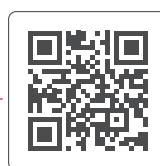

MADE IN **GERMANY**

perma STAR VARIO is a single-point, automatic lubricator suited to a broad range of bearing and chain applications. perma STAR VARIO is ideal for applications which demand precise grease delivery or for operating environments which include significant temperature fluctuations. The remote installation kits for perma STAR VARIO provide practical solutions for lubricators to be installed at safe and easy to reach locations.



Conveyor pulley bearings and seals



Pump bearings and seals



Extraction fan



LCD display with push button control provides time settings in months and weeks for 60, 120, 250 and 500 cm<sup>3</sup> sizes

Display provides confirmation of lubricator status including 'days since red' for empty lubricators

Broad range of setting options reduces compromise when selecting lubricant dispensing rates and service planning



Electromechanical, reusable drive unit provides precise dispensing, independent of temperature and back pressure<sup>†</sup>

Red / green lights in four locations indicate operational status when in areas of poor light



Extensive options for direct and remote mounting provides safe access to lubricators and protects them from damage (refer to pg 36)

Pressure build-up to 7.5 bar allows remote mounting with lines up to 5 meters<sup>†</sup>

Purge feature to deliver supplementary grease as required

<sup>†</sup> Limits depend on line ID, grease type, temperature and the resistance to flow presented by lubrication point itself. Extending line lengths delays the delivery of first grease and may prevent lubricant delivery altogether



**Drive – reusable**

Electromechanical drive with 4.5 V battery pack (Alkaline)



**Discharge period**

1, 2, 3 ... 12 months | 1, 2, 3 ... 52 weeks  
STAR LC 500: max. 6 months | 26 weeks



**Lubricant volume**

60, 120, 250, 500 cm<sup>3</sup>



**Operating temperature**

-20 °C to +60 °C



**Remote installations**

5 meters of 3/8" ID line (grease)<sup>†</sup>



**Protection class**

IP 65



**Standard & special lubricants**

Greases up to NLGI 2 | Oils

**Dimensions**

LC 60: Ø 75 x 155 mm | LC 120: Ø 75 x 178 mm  
LC 250: Ø 75 x 228 mm | LC 500: Ø 75 x 324 mm

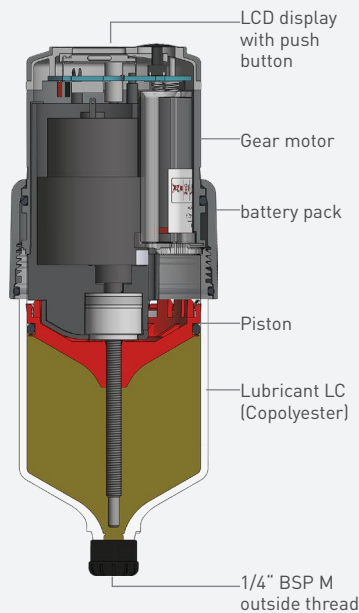

**STAR VARIO drive unit reusable**



**Battery pack STAR VARIO single use**



**STAR Lubricant canister (LC) single use**



**Support flange STAR reusable**



## perma STAR CONTROL

PLC / machine controlled lubricant delivery

Similar to the perma STAR VARIO, the perma STAR CONTROL delivers precise amounts of lubricant and its operation is temperature independent. The unique feature of the perma STAR CONTROL is its connection to machine control. This feature makes the perma STAR CONTROL ideally suited to equipment where re-lubrication is to take place only when the machine is in operation, for critical equipment which has low utilisation or for standby equipment.

The perma STAR CONTROL consists of an electromechanical drive and a lubricant canister with 60 , 120, 250 or 500 cm<sup>3</sup> of lubricant. The perma STAR CONTROL has two operating modes: TIME and IMPULSE.

More information can be found on  
our website [www.perma.com.au](http://www.perma.com.au)

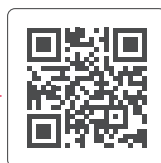

**MADE IN GERMANY**

perma STAR CONTROL is a PLC controlled single-point, automatic lubricator. There are two modes of operation available via the SET button menu – TIME and IMPULSE. In IMPULSE mode, the lubricator discharges a set volume of lubricant as soon as voltage is applied. Before it will discharge again, voltage must be interrupted for at least 5 seconds and then reapplied. TIME mode dispenses lubricant at a set rate of cm<sup>3</sup> per 100 hours of machine operation, stopping and starting at preset intervals.



Chain lubrication



Fan bearings



Electric motor bearings



Simple push button setting in TIME or IMPULSE mode for 60, 120, 250 and 500 cm<sup>3</sup> sizes

TIME based dispensing mode delivers lubrication rates as per the standard perma STAR VARIO, but only when equipment is operational

Machine control via PLC interface allows lubrication to occur only when equipment is operational



Basic lubricator status information is available via the PLC interface

Electromechanical, reusable drive unit provides precise dispensing which is independent of temperature and back pressure<sup>†</sup>



Pressure build-up to 7.5 bar allows remote mounting with lines up to 5 meters<sup>†</sup>

Extensive options for direct and remote mounting provides safe access to lubricators and protects them from damage (refer to pg 36)

Purge feature to deliver supplementary grease as required

<sup>†</sup> Limits depend on line ID, grease type, temperature and the resistance to flow presented by lubrication point itself. Extending line lengths delays the delivery of first grease and may prevent lubricant delivery altogether



**Drive – reusable**

Electromechanical function  
external voltage: 9-30 V DC, I<sub>max</sub> 0.5 A



**Discharge period**

Timed (TIME mode)  
Pulse (IMPULSE mode)



**Lubricant volume**

60, 120, 250, 500 cm<sup>3</sup>



**Operating temperature**

-10 °C to +60 °C



**Remote installations**

5 meters of 3/8" ID line (grease)<sup>†</sup>



**Protection class**

IP 65



**Standard & special lubricants**

Greases up to NLGI 2 | Oils

**Dimensions**

LC 60: Ø 75 x 155 mm | LC 120: Ø 75 x 178 mm  
LC 250: Ø 75 x 228 mm | LC 500: Ø 75 x 324 mm

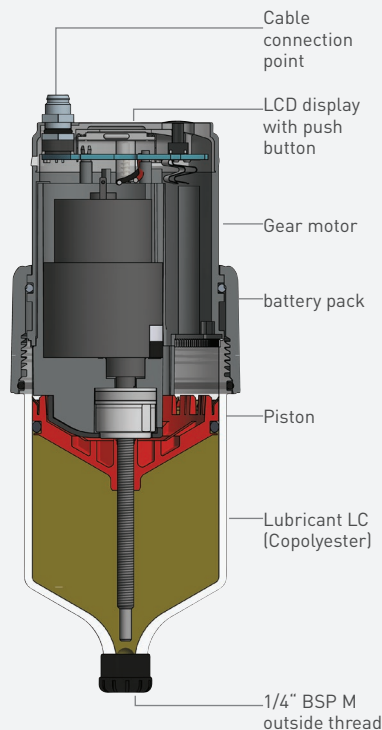

# CONNECTING BEYOND BOUNDRIES.

Safe. Smart. Reliable.



perma CONNECT  
DESKTOP VERSION

The perma CONNECT system architecture allows perma Bluetooth and LoRaWAN enabled lubrication systems to be seamlessly integrated into a single lubricator management system. Implementation of perma CONNECT provides significant benefits in the areas of workplace safety and preventative maintenance.

The risk of lubrication systems being left empty or in a fault status for extended periods is substantially reduced because the operational status of the lubrication systems is shown in a clear and simple to navigate way on the perma CONNECT dashboard, facilitating quick and targeted action.

### Remote monitoring

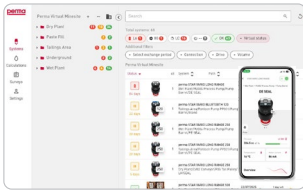

Monitor connected lubricators via perma CONNECT

Status, fill level, history and other system information available at your fingertips

Search, sort and filter features facilitate desktop audits to maintain lubrication program integrity

Identify any missed services and lubricators accidentally turned off

### Remote control



Control connected lubricators via perma CONNECT

Turn lubricators ON/OFF, trigger a PURGE or change lubricator settings.

Initiate PURGE cycles in response to condition monitoring reports of lubrication starvation

Use multi-device commands to turn lubricators OFF / ON for extended shutdowns

### Safer lubrication



Fewer physical lubricator inspections required

Reduced requirement to access difficult locations for routine lubricator inspections

Audits, to confirm lubricator settings, are performed without entering operational areas

Lubricators can be controlled without entering operational areas

## perma CONNECT system architecture

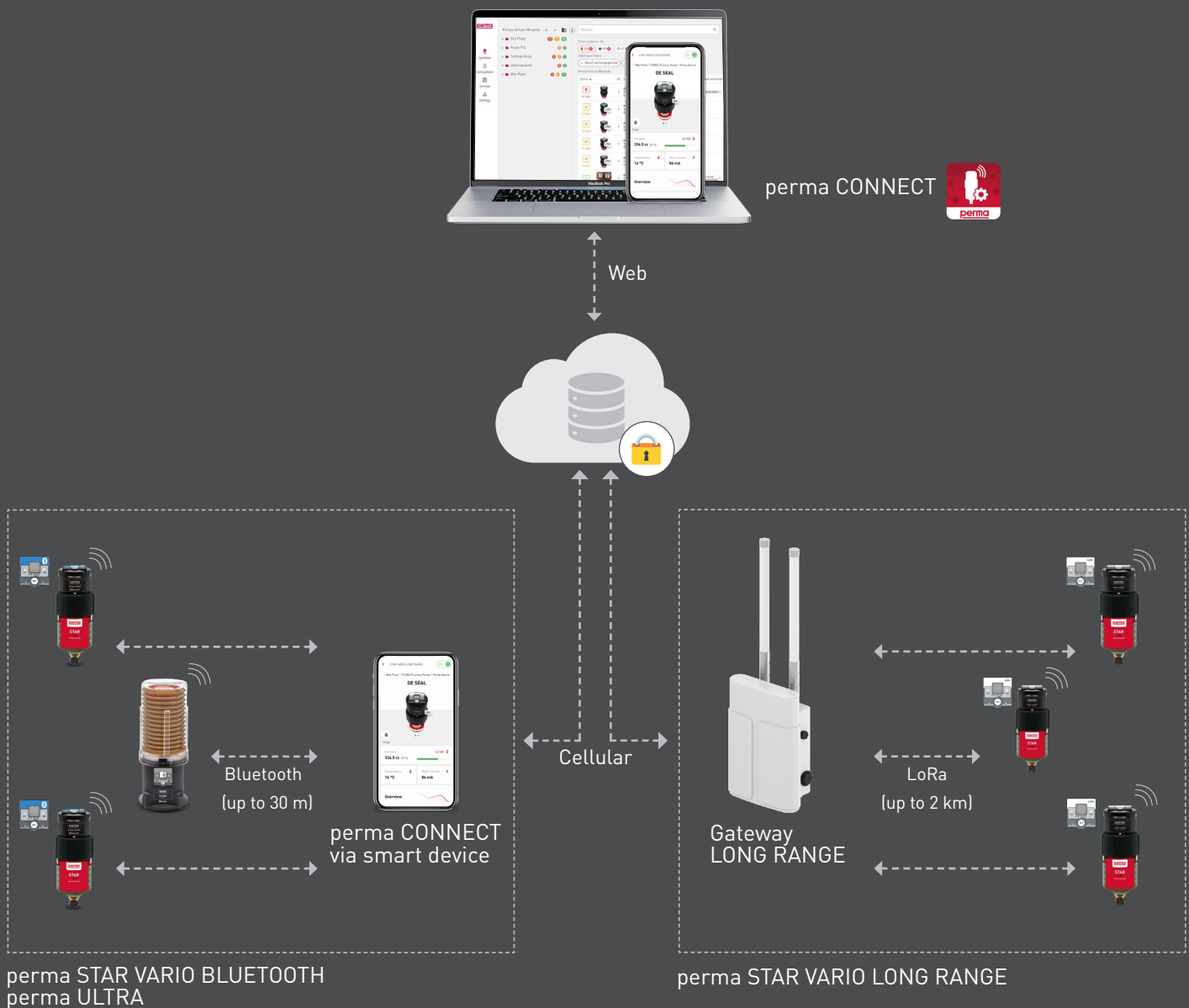



## perma STAR VARIO LONG RANGE

Electro-mechanical, weekly and monthly time settings, four cartridge sizes with Ex-certification and LoRa connectivity

perma STAR VARIO LONG RANGE combines all the performance features of the perma STAR VARIO (refer P18) with the new features of LoRa connectivity, a backlit display and Ex-certification for Zones 2 and 22. The system utilises LoRaWAN network architecture in which gateways relay messages between the perma STAR VARIO LONG RANGE lubrication system and the central network server.

System users can view the operational status of all connected lubricators via the perma CONNECT application. For each perma STAR VARIO LONG RANGE lubrication system, a status update is sent hourly, or whenever a status change occurs. Remote control of the drive unit is also achieved via the perma CONNECT application which includes turning the device on/off, changing settings or even running a purge cycle.

More information can be found on our website [www.perma.com.au](http://www.perma.com.au)

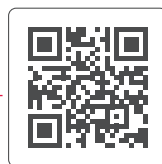

**MADE IN GERMANY**



LoRaWAN infrastructure utilizes AES128 data encryption and complies with ISO / IEC27001 data security requirements

LoRa connectivity allows for remote monitoring and control of lubrication systems

Perform desktop audits via the perma CONNECT application



Each gateway can receive data from 8 lubricators simultaneously and support up to a total of 2000 lubrication systems

Gateways relay status updates and control commands to and from lubricators up to a 2 km radius<sup>†</sup>

Utilise 4G cellular backhaul via the provided data SIM card



Intrinsically safe drive system suitable for use in Zone 2 (gases/vapours) and Zone 22 (dusts) hazardous areas.

Lubricator status confirmation and control via non-Ex gateway located outside of the hazardous areas.

Refer to IECEx certificate for further detail

<sup>†</sup> LoRa communication up to 2 km line-of-sight. Dependent on a number of factors, including signal interference and density of obstructions/structures between the gateways and lubricators

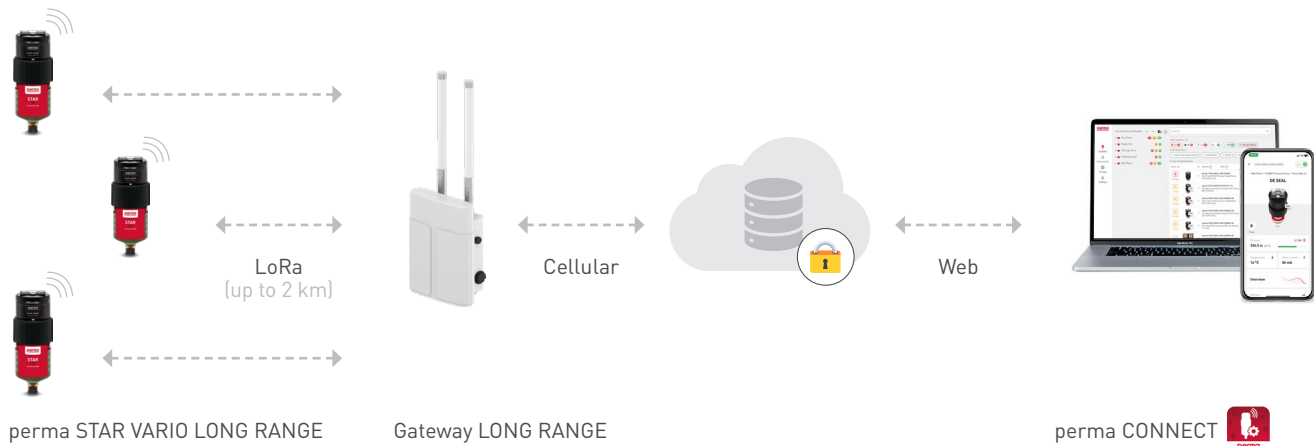

**Drive – reusable**

Electro-mechanical drive with 4.5 V battery pack (Alkaline)



**Discharge period**

1, 2, 3 ... 12 months | 1, 2, 3 ... 52 weeks  
STAR LC 500: max. 6 months | 26 weeks



**Lubricant volume**

60, 120, 250, 500 cm<sup>3</sup>



**Operating temperature**

-20 °C to +60 °C



**Remote installations**

5 meters of 3/8" ID line (grease)<sup>†</sup>



**Protection class**

IP 65



**Standard & special lubricants**

Greases up to NLGI 2 | Oils

**Dimensions**

LC 60: Ø 75 x 155 mm | LC 120: Ø 75 x 178 mm  
LC 250: Ø 75 x 228 mm | LC 500: Ø 75 x 324 mm

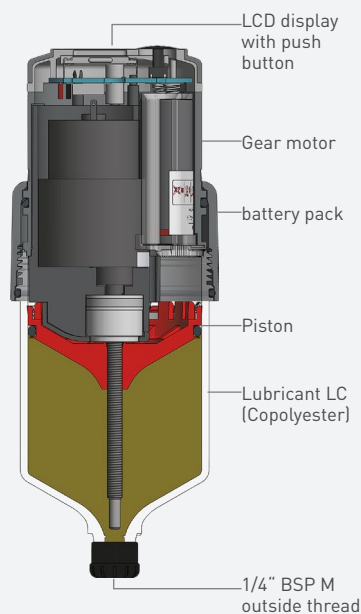

**Gateway LONG RANGE**  
permanent installation



**STAR VARIO LONG RANGE**  
drive unit reusable



**Battery pack STAR VARIO**  
single use



**STAR Lubricant canister (LC)**  
single use



**Support flange STAR**  
reusable



## perma STAR VARIO BLUETOOTH

Electro-mechanical, weekly and monthly time setting options, four cartridge sizes and Bluetooth

perma STAR VARIO BLUETOOTH combines all of the performance features of the perma STAR VARIO and the new features of Bluetooth connectivity and a backlit display. The remote installation options provide opportunities to improve workplace safety by installing the systems at safe and easy to access locations. Use of the system is simple and intuitive with programming via the set button or the perma CONNECT APP.

The operational status of the system is communicated in a variety of convenient ways. Users of the system can view the status via the Bluetooth feature using the perma CONNECT APP. Alternatively, without using the App, the combination of the back-lit display and the bright red and green signal lights provide immediate confirmation of the system status.

More information can be found on our website [www.perma.com.au](http://www.perma.com.au)

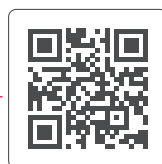

**MADE IN GERMANY**

perma STAR VARIO BLUETOOTH is a single-point, automatic lubricator suited to a broad range of bearing and chain applications where wireless connection for system status confirmation and control is required. perma STAR VARIO BLUETOOTH is ideal for equipment which is difficult or time consuming to access for the purpose of lubricator inspection.



Conveyor pulley bearings and seals



Electric motor bearings



Extraction fan



Backlit LCD display with push button control provides time settings in months and weeks for 60, 120, 250 and 500 cm<sup>3</sup> sizes

Broad range of setting options reduces compromise when selecting dispensing rates and provides service planning flexibility

Display provides confirmation of lubricator status including 'days since red' for empty lubricators



perma CONNECT displays operational details of lubricators via smart devices or desktop computers

Lubricator can be controlled via perma CONNECT, including turning ON / OFF, initiating purge and changing dispensing rates

Bluetooth connection provides lubricator status, remaining lubricant, date of last connection and dispensing history



Extensive options for direct and remote mounting provides safe access to lubricators and protects them from damage (refer to pg 36)

Pressure build-up to 7.5 bar allows remote mounting with lines up to 5 meters<sup>†</sup>

Purge feature to deliver supplementary grease as required

<sup>†</sup> Limits depend on line ID, grease type, temperature and the resistance to flow presented by lubrication point itself. Extending line lengths delays the delivery of first grease and may prevent lubricant delivery altogether



**Drive – reusable**

Bluetooth electromechanical drive with 4.5 V battery pack (Alkaline)



**Discharge period**

1, 2, 3 ... 12 months | 1, 2, 3 ... 52 weeks  
STAR LC 500: max. 6 months | 26 weeks



**Lubricant volume**

60, 120, 250, 500 cm<sup>3</sup>



**Operating temperature**

-20 °C to +60 °C



**Remote installations**

5 meters of 3/8" ID line (grease)<sup>†</sup>



**Protection class**

IP 65



**Standard & special lubricants**

Greases up to NLGI 2 | Oils

**Dimensions**

LC 60: Ø 75 x 155 mm | LC 120: Ø 75 x 178 mm  
LC 250: Ø 75 x 228 mm | LC 500: Ø 75 x 324 mm

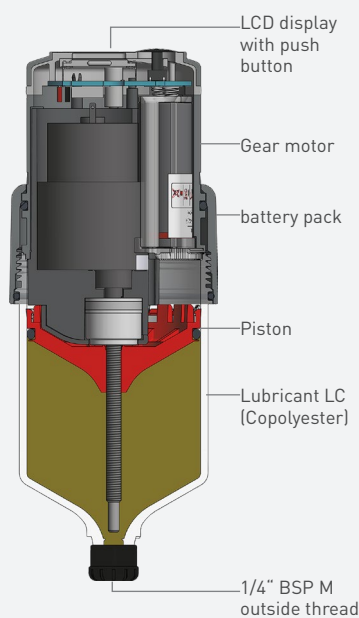

**STAR VARIO BLUETOOTH drive unit reusable**



**Battery pack STAR VARIO single use**



**STAR Lubricant canister (LC) single use**



**Support flange STAR reusable**

# Dispensing Rates

## Weekly Settings

This dispensing rate data applies to the perma STAR VARIO, perma STAR VARIO BLUETOOTH and perma STAR VARIO LONG RANGE lubrication systems.

Time setting, weeks	Daily dispensing rate, cm <sup>3</sup> per day			
	60 cm <sup>3</sup>	120 cm <sup>3</sup>	250 cm <sup>3</sup>	500 cm <sup>3</sup>
1	8.57	17.14	35.71	71.43
2	4.29	8.57	17.86	35.71
3	2.86	5.71	11.90	23.81
4	2.14	4.29	8.93	17.86
5	1.71	3.43	7.14	14.29
6	1.43	2.86	5.95	11.90
7	1.22	2.45	5.10	10.20
8	1.07	2.14	4.46	8.93
9	0.95	1.90	3.97	7.94
10	0.86	1.71	3.57	7.14
11	0.78	1.56	3.25	6.49
12	0.71	1.43	2.98	5.95
13	0.66	1.32	2.75	5.49
14	0.61	1.22	2.55	5.10
15	0.57	1.14	2.38	4.76
16	0.54	1.07	2.23	4.46
17	0.50	1.01	2.10	4.20
18	0.48	0.95	1.98	3.97
19	0.45	0.90	1.88	3.76
20	0.43	0.86	1.79	3.57
21	0.41	0.82	1.70	3.40
22	0.39	0.78	1.62	3.25
23	0.37	0.75	1.55	3.11
24	0.36	0.71	1.49	2.98
25	0.34	0.69	1.43	2.86
26	0.33	0.66	1.37	2.75
28	0.31	0.61	1.28	-
30	0.29	0.57	1.19	-
32	0.27	0.54	1.12	-
34	0.25	0.50	1.05	-
36	0.24	0.48	0.99	-
38	0.23	0.45	0.94	-
40	0.21	0.43	0.89	-
42	0.20	0.41	0.85	-
44	0.19	0.39	0.81	-
46	0.19	0.37	0.78	-
48	0.18	0.36	0.74	-
50	0.17	0.34	0.71	-
52	0.16	0.33	0.69	-

# Dispensing Rates

## Monthly Settings

This dispensing rate data applies to the perma STAR VARIO, perma STAR VARIO BLUETOOTH and perma STAR VARIO LONG RANGE lubrication systems.

Time setting, months	Daily dispensing rate, cm <sup>3</sup> per day			
	60 cm <sup>3</sup>	120 cm <sup>3</sup>	250 cm <sup>3</sup>	500 cm <sup>3</sup>
1	2.0	4.0	8.3	16.45
2	1.0	2.0	4.2	8.22
3	0.67	1.3	2.8	5.48
4	0.50	1.0	2.1	4.11
5	0.40	0.80	1.7	3.29
6	0.33	0.67	1.4	2.74
7	0.29	0.57	1.2	-
8	0.25	0.50	1.0	-
9	0.22	0.44	0.93	-
10	0.20	0.40	0.83	-
11	0.18	0.36	0.76	-
12	0.17	0.33	0.69	-

## LUBRICATING THE WHEELS OF RESEARCH

perma FLEX is made in Germany and is ideal when a compact, lightweight, automatic lubricator is required for direction mounting to lubrication points.







The perma FLEX holds a special position in the perma portfolio of products due to the direct link to our corporate partnership with the National Breast Cancer Foundation.

A proud partner since 2019, the contributions of HTL perma Australia are more than **\$250,000**.



# Lubricator Operational Status

## Display and Light Sequences

Lights & Display Screen	Lubricator Status	Action	
	<p><b>DISPLAY</b> Shows the time setting and a flashing line above the lubricant canister size.</p> <p><b>LIGHTS</b> <b>Green</b> 7 seconds</p>	<p><b>DWELL</b> Lubricator is between dispensing cycles, waiting to commence the next programmed lubricant delivery cycle.</p>	<p>Inspect integrity of lubricator, grease line and fittings. Mark and date the position of the piston to identify that an inspection has been completed.</p>
	<p><b>DISPLAY</b> <b>RU</b> = run</p> <p><b>LIGHTS</b> <b>Green</b> 1 seconds</p>	<p><b>DISPENSING</b> Lubricator is dispensing lubricant.</p>	<p>Wait for run cycle to finish and inspect.</p>
	<p><b>DISPLAY</b> <b>PU</b> = purge</p> <p><b>LIGHTS</b> <b>Green</b> 1 seconds</p>	<p><b>PURGE</b> Lubricator purge mode has been activated and lubricant is being dispensed.</p>	<p>PURGE is activated by holding down the SET button for 10 seconds to deliver 6 cm<sup>3</sup>. The purge cycle can be interrupted at any time by pressing the SET button.</p>
	<p><b>DISPLAY</b> <b>LC</b> = lubricant = canister</p> <p><b>LIGHTS</b> <b>Red</b> 2 seconds</p>	<p><b>CANISTER EMPTY</b> Based on the programmed setting the canister should be empty.</p>	<p>Service the lubricator using a new canister and a new battery set. <b>To reset the lubricator for the next canister a new battery set must be inserted.</b></p>
	<p><b>DISPLAY</b> <b>OL</b> = overload</p> <p><b>LIGHTS</b> <b>Red</b> 7 seconds</p>	<p><b>OVERLOAD</b> The lubricator has experienced high resistance from the lubrication point and has been unable to deliver the lubricant.</p>	<p>Manually purge the point to clear the blockage. The lubricator can be restarted by turning it on and off again. If the overload persists the cause of the blockage must be addressed.</p>
	<p><b>DISPLAY</b> <b>Lo</b> = low battery</p> <p><b>LIGHTS</b> <b>Red</b> 2 seconds</p>	<p><b>LOW BATTERY</b> The inserted battery set is either already depleted or damaged.</p>	<p>Replace with a new battery set.</p>

## Days since empty count



It is recommended to always write the installation date on the cartridge of perma STAR VARIO lubricators. This provides valuable information to personnel involved in lubricator inspections. In particular, if a lubricator is found to be empty, the recorded date allows the period for which lubricant has not been delivered to be determined, which in turn allows the equipment maintainer to determine the appropriate maintenance action.

For occasions where an installation date has not been recorded the perma STAR VARIO<sup>+</sup> provides a count of the number of days for which the cartridge has been empty. Refer below for details.

<sup>†</sup>This feature is only available for perma STAR VARIO drive units with software version 3.4 onwards. Contact your supplier of perma products for more information.

## Information from empty lubricators



As shown in the table opposite, when the lubricant cartridge is empty the lubricator display screen shows LC and the LEDs flash red every 2 seconds.

When LC is displayed the time setting and count of the number of days that the cartridge has been empty can be obtained. This information assists equipment maintainers to make decisions about the most appropriate action when lubricators are found to be empty, especially when lubricant cartridges have not been clearly marked with the installation date.

To confirm the lubricator time setting press and hold the SET button for 1 second, then release the SET button to confirm the number of days since empty. The display will automatically alternate between "rd" and the day count, up to a maximum of 99 days. After alternating between "rd" and the day count eight times the display will return to "LC". **rd** = days count since **red**.

**Example** - A 250 cc lubricator is found to be empty, displaying LC, with no date markings on the lubricant cartridge. By holding the SET button down for 1 second it is confirmed that the time setting is 6 months and that the lubricator has been empty for 2 days. The display sequence is shown below.

This information would indicate to the equipment maintainer that no special action is required other than the normal lubricator servicing procedure.

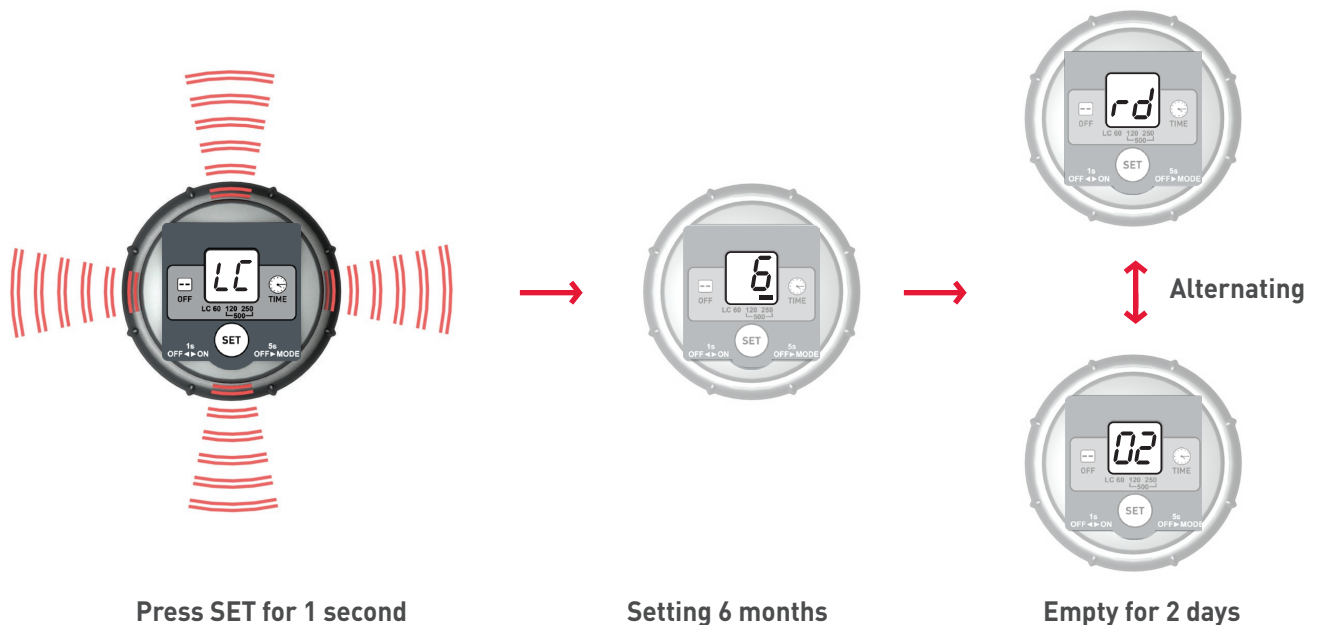

# perma Installation Kits

## Overview

### A. Full length protection covers

Covers to protect lubricators from solid and liquid contaminants.

### B. Manual purge point

Used for convenient additions of supplementary grease, line purging and grease blockage clearing.

### C. Elbows

Elbow fittings are full bore with 1/4" BSP threads.

### D. Stainless steel bracket

There are two main categories of brackets – Standard Duty and Heavy Duty. The example shown here is the Heavy Duty C-section design.

### E. Stainless steel beam clamps

Simple to use beam clamps supplied with stainless steel set screws and assembly screws.

### F. Support flanges & cover clips

Support flanges provide support against damage by impacts or vibration. Cover clips improve contamination control and retain full length covers.

### G. Heavy duty hose

Quality Ryco brand hose. Supplied with 3/8" internal diameter and push-lock type swivel hose ends.

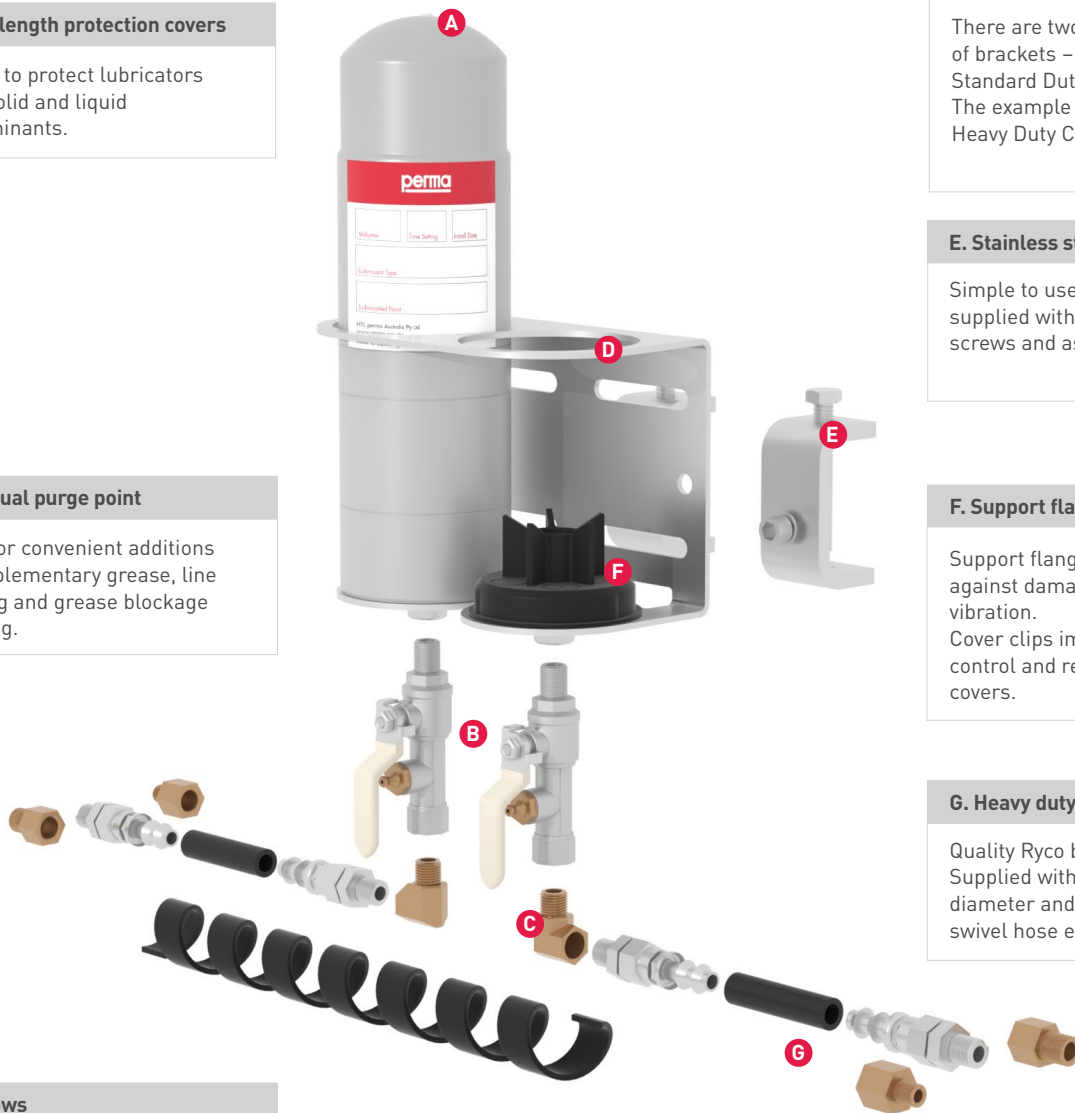

Remote installation kits are designed to be installed with maximum time efficiency. Kit brackets and covers have been designed to provide suitable protection to the lubricator against accidental damage and contamination build-up. Grease line type and fittings have been carefully selected to minimise resistance to grease flow.

Installation kits shown are compatible with perma STAR VARIO, perma STAR VARIO BLUETOOTH and perma STAR VARIO LONG RANGE automatic lubrication systems.

## Introduction

A comprehensive range of remote installation kits is available for the perma STAR VARIO lubricator range. Available in 1, 2, 3 and 4 point configurations, the kits are designed to be simple to implement and to provide long term durability.

The brackets included in kits are stainless steel and are secured to beam sections, cage mesh or round rails using simple attachment methods. Installations can be completed quickly, without the need for power tools or hot work.

## What is included in installation kits for the perma STAR VARIO lubricator range?

The list below summarise the components included in perma STAR VARIO remote installation kits. Meanwhile, the image opposite provides an diagrammatic example of the components – the example shown has the part number K265C.

- Stainless steel bracket
- Attachment option (beam clamps, cage hooks or U-bolts)
- Manual purge points (one per point)
- Lubricator support flanges (one per point)
- Full length covers (one per point)
- Grease line (2 meters per point)
- Push lock, swivel hose ends with adaptor to 1/4" BSP male (2 per point)
- Spiral wrap (0.5 meter per kit)
- Adaptors 1/4" BSP female to 1/4" BSP male (one per point)
- Reducers 1/4" BSP female to 1/8" BSP male (one per point)
- Elbows 90°C full bore 1/4" BSP (one per point)

## Bracket types - Standard Duty & Heavy Duty

There are two main categories of brackets: Standard Duty and Heavy Duty. Both categories include stainless steel construction, 1/4" BSP female sockets and laser cut profiles to minimise contamination build-up. Heavy Duty brackets feature a C-section design which provides a secure holding system for the lubricator covers.

The C-section design is suited to installations which are to be subjected to water wash down, for applications such as slurry pumps in coal preparation plants. This design also provides greater mounting flexibility due to the 4-slot design of the bracket mounting face.



## Custom designs

Brackets and installation kits can be customised to meet the specific needs of different equipment configurations, lubrication strategies and mounting requirements. Customised solutions include manifold brackets, inclusion of pre-assembled & pre-filled grease lines and the inclusion of specific fittings.

### Example

Four point installation kit incorporating two 250 cm<sup>3</sup> and two 500 cm<sup>3</sup> perma STAR VARIO lubrication systems.



# perma Installation Kits

Standard Duty - 60, 120 and 250 cm<sup>3</sup>



Standard Duty installation kits are highly versatile and can be adapted for attachment to beam sections or square mesh safety cages. The brackets included in Standard Duty kits are fabricated in Australia from stainless steel.

Standard Duty kits include lubricator covers and manual purge kits for each lubrication point along with a range of commonly required fittings, push-lock swivel hose ends and high quality Ryco brand hose with 3/8" internal diameter.

Installation kits shown are compatible with perma STAR VARIO, perma STAR VARIO BLUETOOTH and perma STAR VARIO LONG RANGE automatic lubrication systems.

## Standard Duty Beam Mount

The range of Standard Duty kits with beam clamps includes options for 1, 2, 3 or 4 points. Beam clamp options include 30 mm and 65 mm sizes, as indicated by the 3rd and 4th digits of the product part number – **30** for 30 mm clamps and **65** for 65 mm clamps.



K130 (with 30 mm beam clamps)  
K165 (with 65 mm beam clamps)



K230 (with 30 mm beam clamps)  
K265 (with 65 mm beam clamps)



K330 (with 30 mm beam clamps)  
K365 (with 65 mm beam clamps)



K430 (with 30 mm beam clamps)  
K465 (with 65 mm beam clamps)

### Example Installation Kit Contents – K230

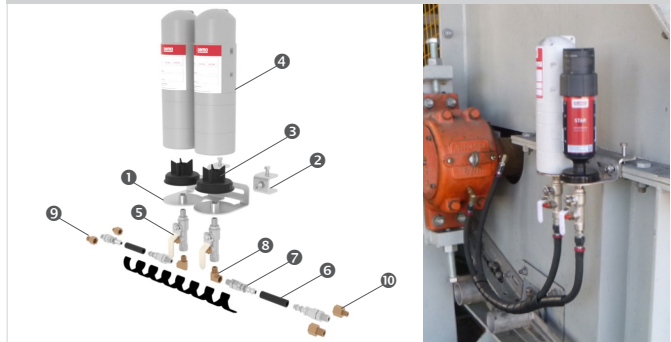

### Bill of Materials

1	1 x 2 point standard duty bracket	6	4 m of 3/8" ID grease line
2	2 x 30 mm SS beam clamps	7	4 x female swivel hose ends
3	2 x lubricator support flanges	8	2 x 90 degree elbows
4	2 x full length covers	9	2 x 1/4" BSPF-1/8" BSPM reducers
5	2 x manual purge kits	10	2 x 1/4" BSPF -1/4" BSPM extension

## Standard Duty Cage Mount

The range of Standard Duty installation kits with cage hooks are suited to square cage down to a mesh size of 25 x 25 mm. Installation kits are available for 1, 2, 3 or 4 points as summarised below. **CH** as the 3rd and 4th digits of the product part number indicates the inclusion of cage hook.



K1CH



K2CH



K3CH



K4CH

### Example Installation Kit Contents – K2CH



### Bill of Materials

1	1 x 2 point standard duty bracket	6	4 m of 3/8" ID grease line
2	2 x cage hanger arms	7	4 x female swivel hose ends
3	2 x lubricator support flanges	8	2 x 90 degree elbows
4	2 x full length covers	9	2 x 1/4" BSPF-1/8" BSPM reducers
5	2 x manual purge kits	10	2 x 1/4" BSPF -1/4" BSPM extension

# perma Installation Kits

Heavy Duty - 60, 120 and 250 cm<sup>3</sup>

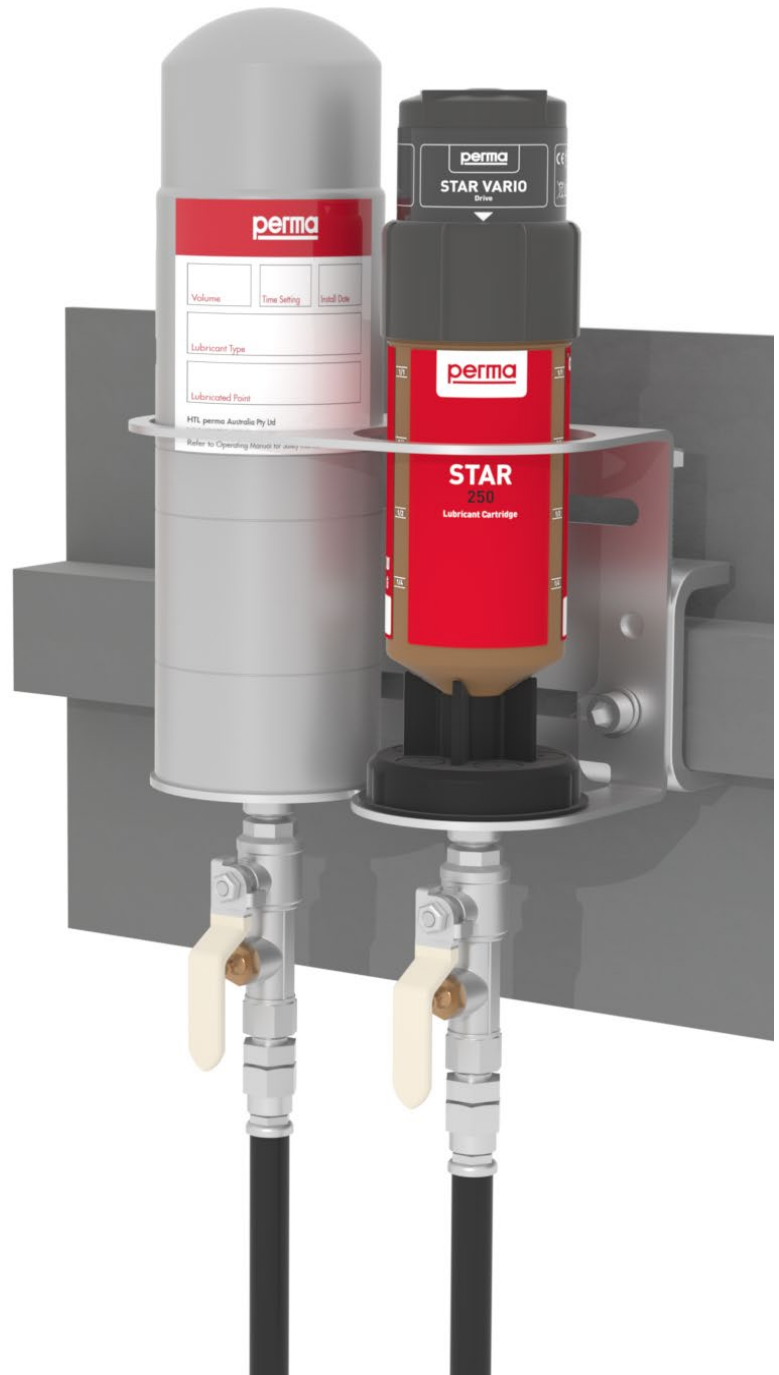

Heavy Duty installation kits have been specifically designed for use in operational areas which are subject to regular wash down and water impact, such as the conditions found in coal handling preparation plants. The installation kits are highly versatile and can be adapted for attachment to beam sections and square mesh safety cages. The bracket systems included in Heavy Duty installation kits are fabricated in Australia from stainless steel.

Heavy Duty installation kits include lubricator covers and manual purge kits for each lubrication point along with a range of commonly required fittings, push-lock swivel hose ends and high quality Ryco brand hose with 3/8" internal diameter.

Installation kits shown are compatible with perma STAR VARIO, perma STAR VARIO BLUETOOTH and perma STAR VARIO LONG RANGE automatic lubrication systems.

## Heavy Duty Beam Mount

The range of Heavy Duty kits with beam clamps includes options for 1, 2, 3 or 4 points. Beam clamp options include 30 mm and 65 mm sizes, as indicated by the 3rd and 4th digits of the product part number – **30** for 30 mm clamps and **65** for 65 mm clamps.



K130C (with 30 mm beam clamps)  
K165C (with 65 mm beam clamps)



K230C (with 30 mm beam clamps)  
K265C (with 65 mm beam clamps)



K330C (with 30 mm beam clamps)  
K365C (with 65 mm beam clamps)



K430C (with 30 mm beam clamps)  
K465C (with 65 mm beam clamps)

### Example Installation Kit Contents – K230C

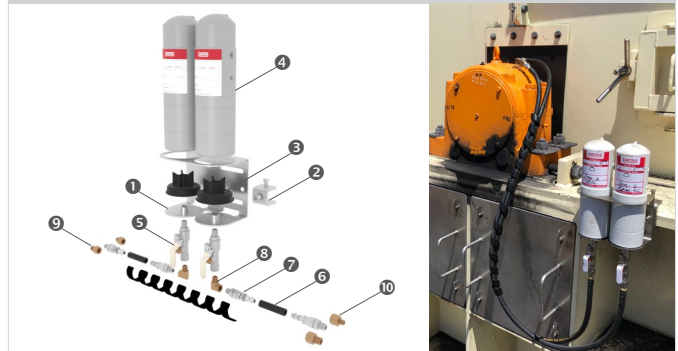

### Bill of Materials

1	1 x 2 point heavy duty bracket	6	4 m of 3/8" ID grease line
2	2 x 30 mm SS beam clamps	7	4 x female swivel hose ends
3	2 x lubricator support flanges	8	2 x 90 degree elbows
4	2 x full length covers	9	2 x 1/4" BSPF-1/8" BSPM reducers
5	2 x manual purge kits	10	2 x 1/4" BSPF -1/4" BSPM extension

## Heavy Duty Cage Mount

The range of Heavy Duty installation kits with cage hooks are suited to square cage down to a mesh size of 25 x 25 mm. Installation kits are available for 1, 2, 3 or 4 points as summarised below. **CH** as the 3rd and 4th digits of the product part number indicates the inclusion of cage hook.



K1CHC



K2CHC



K3CHC



K4CHC

### Example Installation Kit Contents – K2CHC

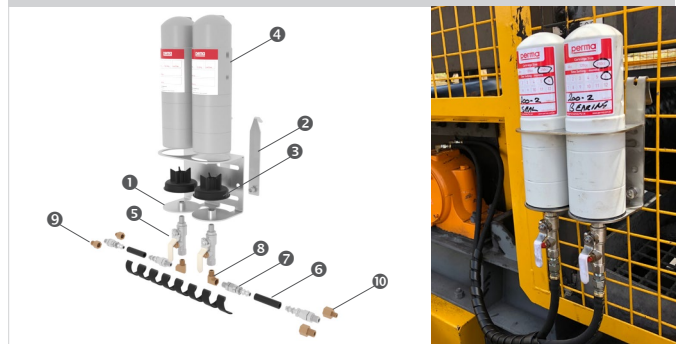

### Bill of Materials

1	1 x 2 point heavy duty bracket	6	4 m of 3/8" ID grease line
2	1 x cage hanger arms	7	4 x female swivel hose ends
3	2 x lubricator support flanges	8	2 x 90 degree elbows
4	2 x full length covers	9	2 x 1/4" BSPF-1/8" BSPM reducers
5	2 x manual purge kits	10	2 x 1/4" BSPF -1/4" BSPM extension

# perma Installation Kits

## Manifold Kits



Installation kits which incorporate two and three point manifolds are available with combinations of standard duty and heavy duty bracket designs, plus the option of beam or cage mount. Manifold installation kits should be considered for use where an elevated grease dispensing rate is required or where a particular service period is to be targeted.

For example, if a lubrication point requires a grease application rate equivalent to a 6 week setting, but the target minimum service period for the equipment is 12 weeks, a 2-point manifold arrangement can be utilised with a 12 week time setting.

Installation kits shown are compatible with perma STAR VARIO, perma STAR VARIO BLUETOOTH and perma STAR VARIO LONG RANGE automatic lubrication systems.

## Manifold Beam Mount

Beam clamp options include 30 mm and 65 mm sizes, as indicated by the 3rd and 4th digits of the product part number – 30 for 30 mm clamps and 65 for 65 mm clamps. The inclusion of a C in the part number indicates a heavy duty C-section brackets and the inclusion of a J indicates that the bracket is a manifold design ( J = joined ).



K230J (with 30 mm beam clamps)  
K265J (with 65 mm beam clamps)



K330J (with 30 mm beam clamps)  
K365J (with 65 mm beam clamps)



K230CJ (with 30 mm beam clamps)  
K265CJ (with 65 mm beam clamps)



K330CJ (with 30 mm beam clamps)  
K365CJ (with 65 mm beam clamps)

### Example Installation Kit Contents – K230J

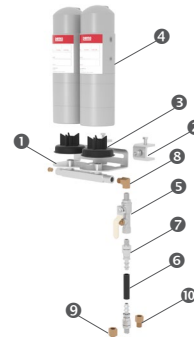

### Bill of Materials

1	1 x 2 point manifold bracket	6	2 m of 3/8" ID grease line
2	2 x 30 mm SS beam clamps	7	2 x female swivel hose ends
3	2 x lubricator support flanges	8	1 x 90 degree elbows
4	2 x full length covers	9	1 x 1/4" BSPF-1/8" BSPM reducers
5	2 x manual purge kits	10	1 x 1/4" BSPF -1/4" BSPM ext.

## Manifold Cage Mount

Cage mount options are suited to square cage mesh down to a size of 25 mm x 25 mm. The inclusion of a C in the part number indicates a heavy duty C-section brackets and the inclusion of a J indicates that the bracket is a manifold design ( J = joined )



K2CHJ

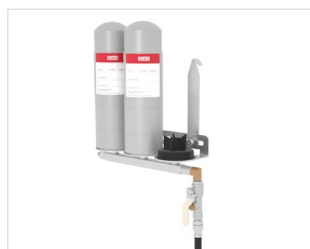

K3CHJ



K2CHCJ



K3CHCJ

### Example Installation Kit Contents – K2CHCJ

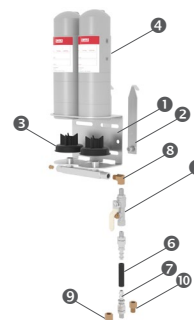

### Bill of Materials

1	1 x 2 point manifold bracket	6	2 m of 3/8" ID grease line
2	1 x cage hanger arms	7	2 x female swivel hose ends
3	2 x lubricator support flanges	8	1 x 90 degree elbows
4	2 x full length covers	9	1 x 1/4" BSPF-1/8" BSPM reducers
5	1 x manual purge kits	10	1 x 1/4" BSPF -1/4" BSPM ext.

# perma Installation Kits

## Direct Mount and Rail Mount Kits



### Direct mount

Where there is safe access to the lubrication point while equipment is operating, direct mounting should be considered. Direct mounting presents maximum grease pressure to the lubrication point and is the lowest cost installation type. Direct mounting should not be implemented where doing so presents a safety compromise or where the risk of damage to the lubrication system is increased due to accidental knocks or impact from process material.

### Rail mount

Rail mount installation kits utilise u-bolts for attaching to round rails with the size range of 30 to 50 mm diameter. Rail mount installation kits should not be installed at locations where the bracket will interfere with access and function of hand rails.

Installation kits shown are compatible with perma STAR VARIO, perma STAR VARIO BLUETOOTH and perma STAR VARIO LONG RANGE automatic lubrication systems.

## Rail Mount Installation Kits

The range of Rail mount kits includes options for 1, 2, 3 or 4 points. Rail mount brackets are secured using U-bolts which are suited to round rails with outer diameters between 30 and 50mm. The rail mount design is indicated by RR as the 3rd and 4th digits of the product part number.

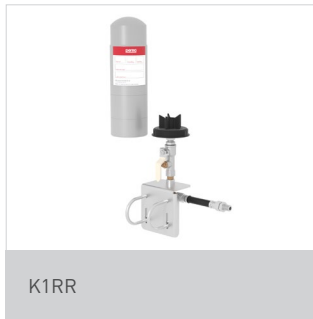

K1RR



K2RR



K3RR

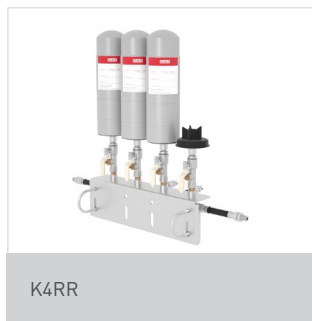

K4RR

### Example Installation Kit Contents – K1RR

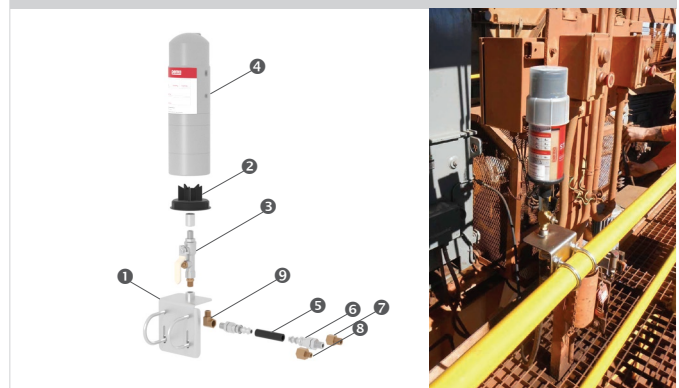

### Bill of Materials

1	1 x 1 point rail bracket	6	2 x female swivel hose ends
2	1 x lubricator support flanges	7	1 x 1/4" BSPF-1/8" BSPM reducers
3	1 x manual purge kits	8	1 x 1/4" BSPF -1/4" BSPM extension
4	1 x full length cover	9	1 x 90 degree elbow
5	2 m of 3/8" ID grease line		

## Direct Mount Installation Kits

Direct mount kits are for single point installations and include a full length cover, cover clip, 1/4" BSP socket, a manual purge kit and various adaptors. The combination provides protection from contamination build-up on the lubricator.

Customised direct mount installation kits, including different reducer and elbow fitting combinations, are available upon request.



KDSV-708V



KDSV-45-708V

### Kit Contents – KDSV-708V



### Bill of Materials

1	1 x full length cover
2	1 x support flange 1/4" BSP
3	1 x round socket 1/4" BSP
4	1 x manual purge kit
5	1 x grease nipple 1/4" BSPM
6	1 x hex nipple 1/4" M to 1/4" M
7	1 x 1/4" BSPF to 1/8" BSPM adaptor

### Kit Contents – KDSV-45-708V

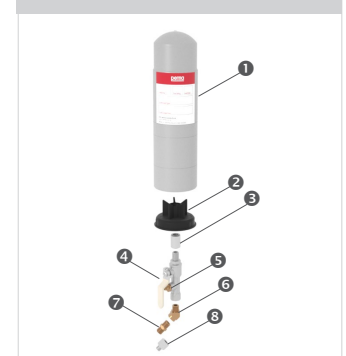

### Bill of Materials

1	1 x full length cover
2	1 x support flange 1/4" BSP
3	1 x round socket 1/4" BSP
4	1 x manual purge kit
5	1 x grease nipple 1/4" BSPM
6	1 x elbow 45° 1/4" BSP
7	1 x hex nipple 1/4" M to 1/4" M
8	1 x 1/4" BSPF to 1/8" BSPM adaptor

# perma Installation Kits

Standard Duty - 500 cm<sup>3</sup>

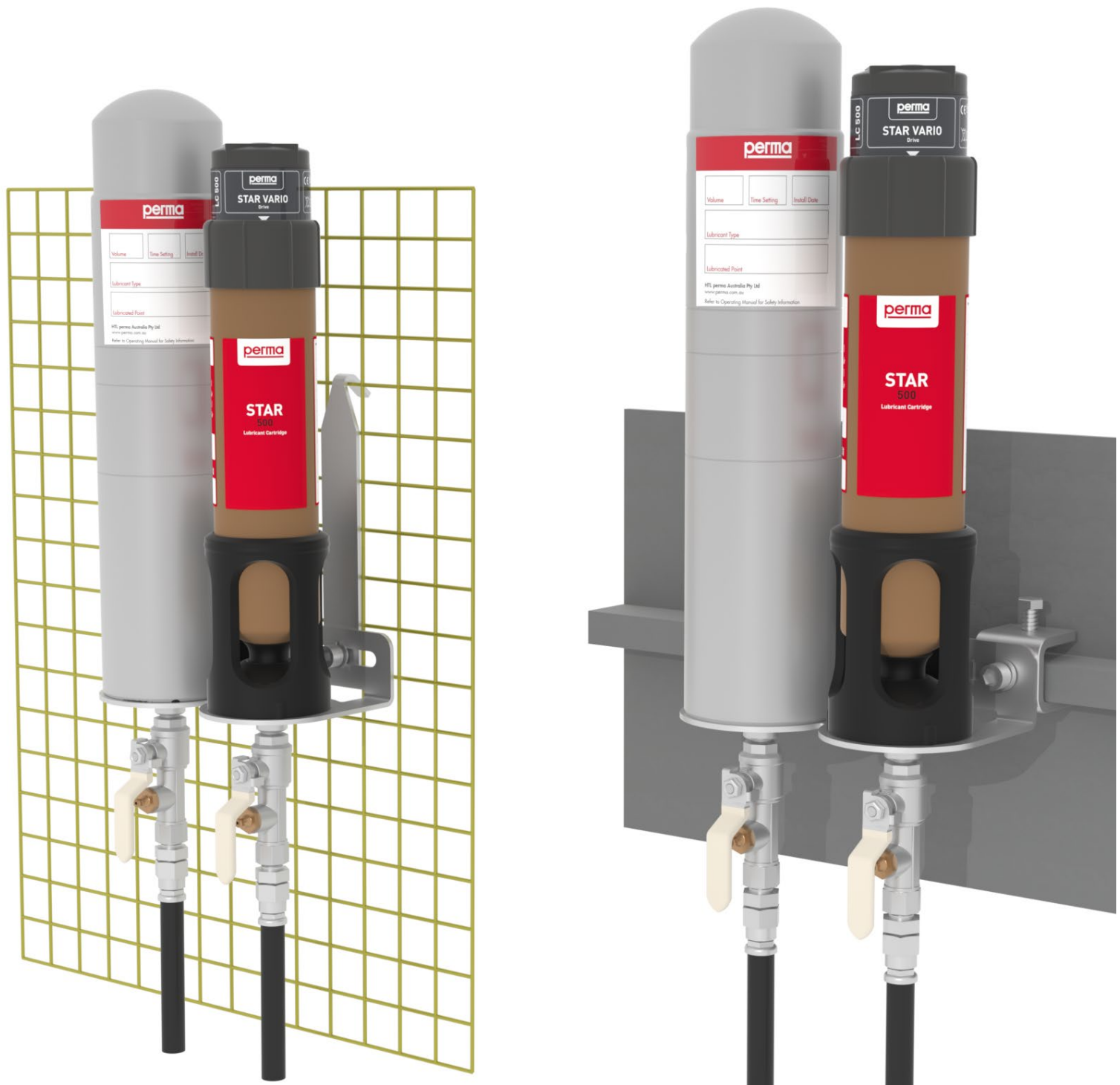

Standard Duty installation kits are highly versatile and can be adapted for attachment to beam sections or square mesh safety cages. The brackets included in Standard Duty kits are fabricated in Australia from stainless steel.

Standard Duty kits include lubricator covers and manual purge kits for each lubrication point along with a range of commonly required fittings, push-lock swivel hose ends and high quality Ryco brand hose with 3/8" internal diameter.

Installation kits shown are compatible with perma STAR VARIO, perma STAR VARIO BLUETOOTH and perma STAR VARIO LONG RANGE automatic lubrication systems.

## Standard Duty Beam Mount

The range of Standard Duty kits with beam clamps includes options for 1, 2, 3 or 4 points. Beam clamp options include 30 mm and 65 mm sizes, as indicated by the 3rd and 4th digits of the product part number – **30** for 30 mm clamps and **65** for 65 mm clamps.



K130X (with 30 mm beam clamps)  
K165X (with 65 mm beam clamps)



K230X (with 30 mm beam clamps)  
K265X (with 65 mm beam clamps)



K330X (with 30 mm beam clamps)  
K365X (with 65 mm beam clamps)



K430X (with 30 mm beam clamps)  
K465X (with 65 mm beam clamps)

### Example Installation Kit Contents – K230X

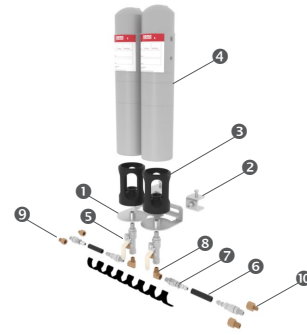

### Bill of Materials

1	1 x 2 point standard duty bracket	6	4m of 3/8" ID grease line
2	2 x 30 mm SS beam clamps	7	4 x female swivel hose ends
3	2 x lubricator support flanges	8	2 x 90 degree elbows
4	2 x full length covers	9	2 x 1/4" BSPF-1/8" BSPM reducers
5	2 x manual purge kits	10	2 x 1/4" BSPF -1/4" BSPM extension

## Standard Duty Cage Mount

The range of Standard Duty installation kits with cage hooks are suited to square cage down to a mesh size of 25 x 25 mm. Installation kits are available for 1, 2, 3 or 4 points as summarised below. **CH** as the 3rd and 4th digits of the product part number indicates the inclusion of cage hook.



K1CHX



K2CHX



K3CHX



K4CHX

### Example Installation Kit Contents – K2CHX

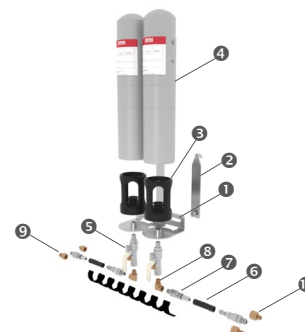

### Bill of Materials

1	1 x 2 point standard duty cage bracket	6	4 m of 3/8" ID grease line
2	2 x cage hanger arms	7	4 x female swivel hose ends
3	2 x lubricator support flanges	8	2 x 90 degree elbows
4	2 x full length covers	9	2 x 1/4" BSPF-1/8" BSPM reducers
5	2 x manual purge kits	10	2 x 1/4" BSPF -1/4" BSPM extension

# perma Installation Kits

Heavy Duty - 500 cm<sup>3</sup>

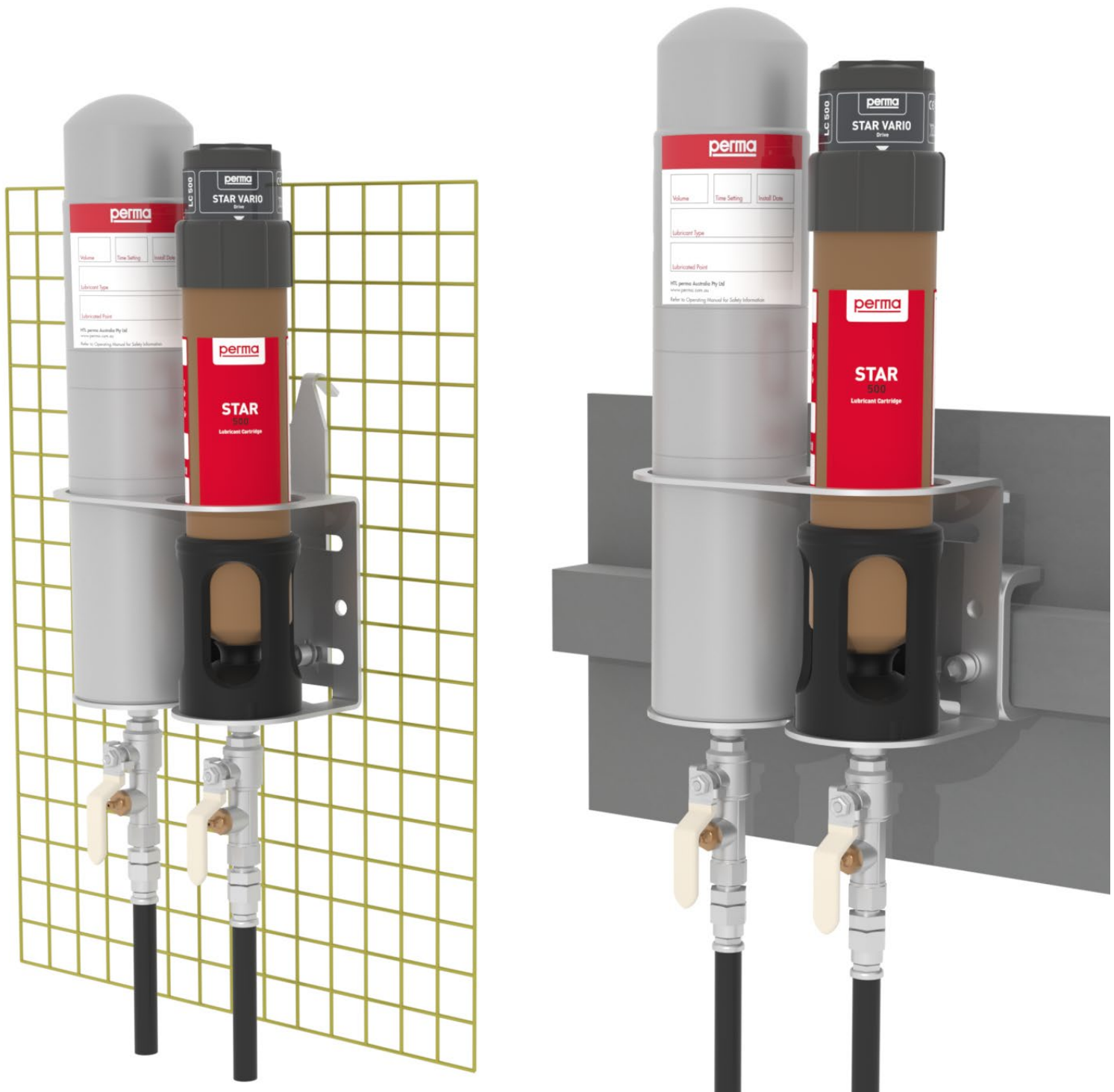

Heavy Duty installation kits have been specifically designed for use in operational areas which are subject to regular wash down and water impact, such as the conditions found in coal handling preparation plants. The installation kits are highly versatile and can be adapted for attachment to beam sections and square mesh safety cages.

Heavy Duty installation kits include lubricator covers and manual purge kits along with a range of commonly required fittings, push-lock swivel hose ends and high quality Ryco brand hose with 3/8" internal diameter.

Installation kits shown are compatible with perma STAR VARIO, perma STAR VARIO BLUETOOTH and perma STAR VARIO LONG RANGE automatic lubrication systems.

## Heavy Duty Beam Mount

The range of Heavy Duty kits with beam clamps includes options for 1, 2, 3 or 4 points. Beam clamp options include 30 mm and 65 mm sizes, as indicated by the 3rd and 4th digits of the product part number – **30** for 30 mm clamps and **65** for 65 mm clamps.



K130CX (with 30 mm beam clamps)  
K165CX (with 65 mm beam clamps)



K230CX (with 30 mm beam clamps)  
K265CX (with 65 mm beam clamps)



K330CX (with 30 mm beam clamps)  
K365CX (with 65 mm beam clamps)



K430CX (with 30 mm beam clamps)  
K465CX (with 65 mm beam clamps)

### Example Installation Kit Contents – K230CX

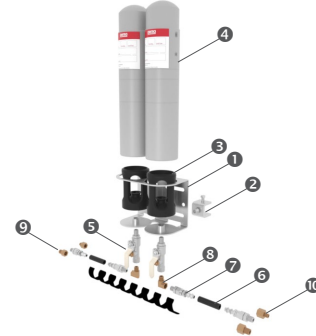

### Bill of Materials

1	1 x 2 point heavy duty bracket	6	4 m of 3/8" ID grease line
2	2 x 30 mm S/S beam clamps	7	4 x female swivel hose ends
3	2 x lubricator support flanges	8	2 x 90 degree elbows
4	2 x full length covers	9	2 x 1/4" BSPF-1/8" BSPM reducers
5	2 x manual purge kits	10	2 x 1/4" BSPF -1/4" BSPM extension

## Heavy Duty Cage Mount

The range of Heavy Duty installation kits with cage hooks are suited to square cage down to a mesh size of 25 mm x 25 mm. Installation kits are available for 1, 2, 3 or 4 points as summarised below. **CH** as the 3rd and 4th digits of the product part number indicates the inclusion of cage hook.



K1CHCX



K2CHCX



K3CHCX



K4CHCX

### Example Installation Kit Contents – K2CHCX

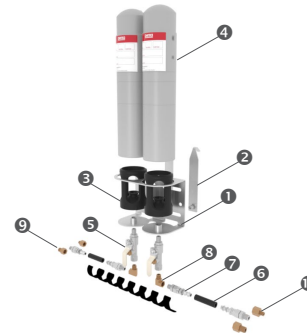

### Bill of Materials

1	1 x 2 point heavy duty bracket	6	4 m of 3/8" ID grease line
2	1 x cage hook arm set	7	4 x female swivel hose ends
3	2 x lubricator support flanges	8	2 x 90 degree elbows
4	2 x full length covers	9	2 x 1/4" BSPF-1/8" BSPM reducers
5	2 x manual purge kits	10	2 x 1/4" BSPF -1/4" BSPM extension

# Remote Installations

## General Guidelines for Remote Installations

Year by year, improvements to safe work practices and increased production demands lead to an increasing requirement to remote mount automatic lubricators so that they can be accessed while equipment is operating. Correct remote mounting practices require that simple, yet important guidelines be followed:

- Locate lubricators where they can be safely and easily accessed while equipment is operating
- Select stainless steel brackets which can be easily removed if required for maintenance access
- Include manual purge points to provide an efficient means of occasional manual purging
- Use only full bore elbow fittings
- Use 3/8" internal diameter grease line and run lines under or around cages

## Remote installation decision making

For many lubrication points it is necessary to mount lubricators at locations which are safe to access while machinery is operating. The questions in the table below can be used to guide mounting decisions. An answer of “yes” to any of the questions indicates that remote mounting is required.

Question	Answer
1. Is it necessary to remove protective guards or safety cages to access the lubrication point?	Yes – remote mount No – direct mount
2. Is it difficult or unsafe to access the lubrication point while equipment is running?	Yes – remote mount No – direct mount
3. Is the lubrication point subject to high vibration or high temperatures which may damage the lubricator?	Yes – remote mount No – direct mount
4. Is it necessary to get permits to access lubrication points such as those in confined spaces or located at heights?	Yes – remote mount No – direct mount
5. Is the lubrication point exposed to excessive amounts of water, process materials or impact from solid material?	Yes – remote mount No – direct mount

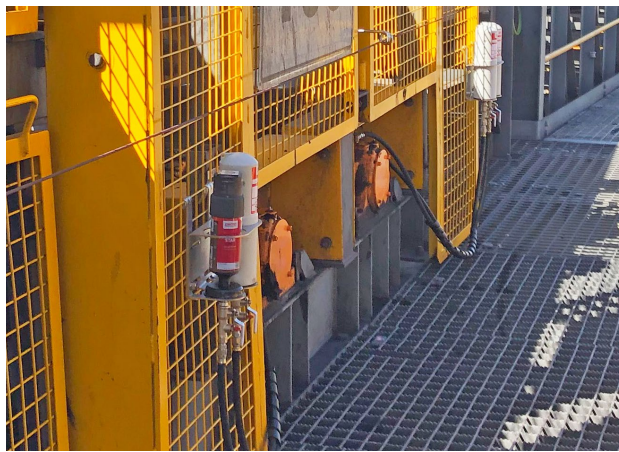

- Select grease line with **3/8" internal diameter**
- Restrict the maximum grease line to a length of **5 meters\*\***
- Select full bore hose end fittings and elbows
- Select stainless steel bracket and locate at a safe point of access
- Route grease lines under or around cage mesh, not through
- Prime grease lines and fittings
- Test the grease delivery path to the lubrication point after priming to ensure that back pressure is not excessive

\*\* This is a guide. Limits depend on variables such as line ID, grease type, temperature and the resistance of the lubrication point itself. Contact your perma supplier for further information.

## General guidelines for remote installations

1. Minimum tools - Personal protective equipment, 2 adjustable wrenches or a metric combination ring/open end spanner set, M8 hex key, hose cutters and grease gun.
2. Identify a suitable bracket mounting position which is safe to access for lubricator servicing:
  - Ensure that there is space above lubricators for covers to be removed.
  - Avoid interference with inspection hatches, frequently removed guards and emergency stop cords.
  - Mount at a height so that the lubricator display can be easily read.
3. Plan grease line routes carefully:
  - Run grease lines under, over or around cages - not through.
  - Secure and protect grease lines using cable ties and spiral wrap.
4. Apply grease to hose end for easy fitting. Cold hose may need to be warmed. Push the hose on using two hands with a firm downwards motion.
5. Fill grease lines with fresh grease and protect hose end fittings with protective wrap in highly corrosive environments.
6. Use a grease gun to test that lubrication points can receive grease freely. Use this opportunity to pre-grease the points if practical to do so.
7. Use a thread locking sealing product to ensure that fittings are secure and to prevent oil weep.
8. Installation kits include reducers from 1/4" BSP F to 1/8" BSP M.†

†A complete range of reducers from 1/4" BSP F, including M6 (part number 2466SS), M8 (part number 2468), M10 (part number 24610) and 1/4" UNF (part number 2461/4UNFSS) are also available.

# Common Equipment & Applications

## Slurry Pumps



Slurry pumps used in operations such as coal preparation plants must endure harsh conditions. Efforts to prevent the entry of water and solid contaminants to pump barrels extends bearing service lives.

The use of automatic lubrication systems to provide a regular purge of fresh grease through the labyrinth seals of pump barrels is a common and proven method of preventing contaminant entry. As the harshness of the operating conditions increases, so does the importance of the automatic purging.

Pumps which are subjected to regular wash down or which have water impingement to the wet-end labyrinth demand higher labyrinth purge rates.

In addition to seal purging, automatic systems can also be implemented for bearing relubrication in order to provide precise and controlled grease delivery, thereby avoiding grease starvation and over lubrication.

## Lubrication assessment criteria

For slurry pump lubrication the following factors are generally assessed in order to develop the lubrication solution:

- Pump manufacturer's recommendations
- Seal types
- Bearing types, grease entry points and grease migration directions
- Characteristics of proposed lubricant
- Typical bearing operating temperatures
- Duty cycle
- Historical lubrication practices
- Desired service schedule
- Operating conditions
- Wash down procedures
- Requirements for safe access

## Installation examples



**Application** Labyrinth seals and mechanical seal  
**Lubricator** perma STAR VARIO 250 cm<sup>3</sup>  
**Installation kit** K230C & direct mount

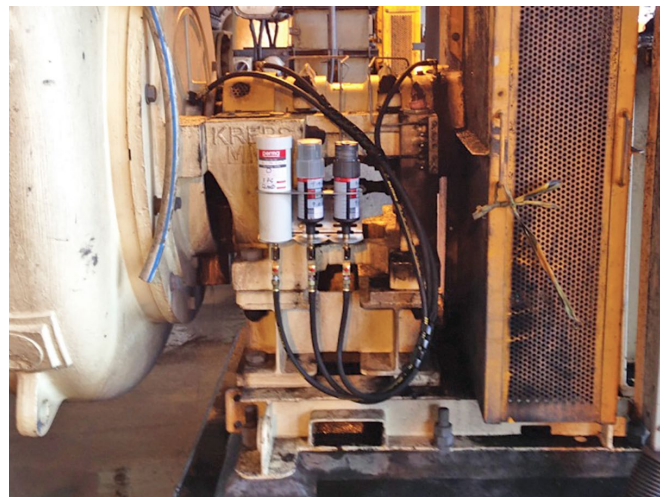

**Application** Labyrinth seals and gland seal  
**Lubricator** perma STAR VARIO 250 cm<sup>3</sup>  
**Installation kit** K365C



**Application** Sump pump  
**Lubricator** perma STAR VARIO 250 cm<sup>3</sup>  
**Installation kit** K230C



**Application** Labyrinth seals  
**Lubricator** perma STAR VARIO 500 cm<sup>3</sup>  
**Installation kit** K265CX

# Common Equipment & Applications

## Conveyor Pulley Bearings



Pulley bearing configurations vary considerably and as such lubrication programs must be designed to take the specific requirements of different bearing and seal combinations into account. For typical spherical roller bearings with labyrinth or taconite seals, the lubrication strategy must address two requirements:

1. The relubrication of the bearing rolling elements to prevent lubricant starvation and;
  2. The regular purging of seals to prevent the entry of contaminants.
- When installing perma STAR VARIO to conveyor pulley bearings the following points should be observed:
- Pre-lubricate the bearing to ensure that it is not in a state of grease starvation from the outset. The aim of the automatic lubrication is to maintain a state of optimal lubrication thereafter
  - For bearings with free purging seals, manually purge the seals until fresh grease is observed around the full circumference of the seal. The aim of the automatic lubrication is to maintain a consistent purge thereafter
  - Select the optimal grease entry point on the housing for bearing relubrication in order to achieve an effective grease flow path. Also, ensure that bearings have been pre-packed in a way which is compatible with the selected grease entry point

## Lubrication assessment criteria

For conveyor pulley bearing lubrication the following factors are generally assessed in order to develop the lubrication solution:

- Bearing types & speeds
- Seal types
- Location of grease entry points on bearing housings
- Characteristics of proposed lubricant
- Operating conditions
- Historical lubrication practices
- Requirements for safe access
- Desired service schedule

## Installation examples

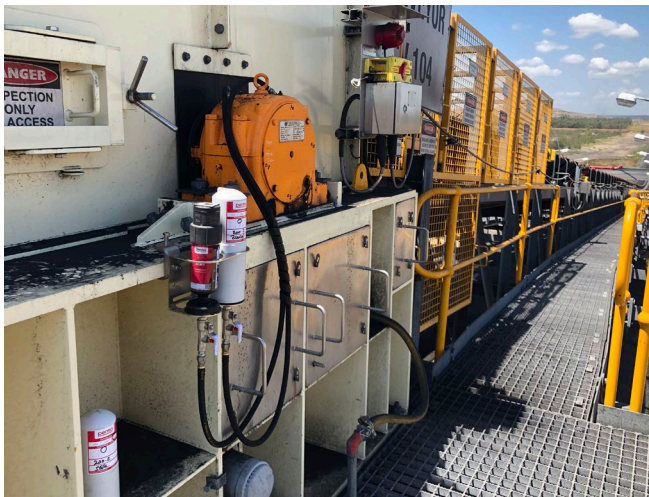

**Application** Conveyor pulley bearing and seal  
**Lubricator** perma STAR VARIO 250 cm<sup>3</sup>  
**Installation kit** K230C



**Application** Conveyor pulley bearing and seal  
**Lubricator** perma STAR VARIO 250 cm<sup>3</sup>  
**Installation kit** K330



**Application** Travel wheels on conveyor tripper  
**Lubricator** perma STAR VARIO BLUETOOTH 250 cm<sup>3</sup>  
**Installation kit** K230



**Application** Conveyor pulley bearings and seals  
**Lubricator** perma STAR VARIO 500 cm<sup>3</sup>  
**Installation kit** 2 x K3CHCX

# Common Equipment & Applications

## Electric Motors



Electric motor bearing relubrication is a critical aspect of maintenance. As with other high speed bearing applications, it is important for relubrication practices to take the risks associated with over-lubrication into account while providing sufficient relubrication to deliver long bearing service life.

The following practices can provide a lubrication program which avoids over-lubrication and lubricant starvation:

- Add small amounts of grease at short time intervals using an automatic lubricator which provides accurate dispensing rates, independent of temperature
- Re-lubricate when the motor is in operation
- Always ensure that spent grease can escape the bearing housing via well maintained grease escape holes or collection traps
- Do not use powered grease guns

## Lubrication assessment criteria

For electric motor lubrication the following factors are generally assessed in order to develop the lubrication solution:

- Motor manufacturer's recommendations
- Motor speed
- Grease trap / escape port design, access and condition
- Bearing types
- Characteristics of proposed lubricant
- Historical lubrication practices
- Duty cycle
- Motor orientation (vertical or horizontal)

## Installation examples



**Application** Electric motor  
**Lubricator** perma STAR VARIO 250 cm<sup>3</sup>  
**Installation kit** K230C



**Application** Electric motor  
**Lubricator** perma STAR VARIO 120 cm<sup>3</sup>  
**Installation kit** Direct mount



**Application** Electric motor  
**Lubricator** perma STAR VARIO 250 cm<sup>3</sup>  
**Installation kit** K230C



**Application** Electric motor  
**Lubricator** perma STAR VARIO 250 cm<sup>3</sup>  
**Installation kit** KDSV-708V

# Common Equipment & Applications

## Fans



Fan support bearings require particular attention when devising a lubrication strategy. Because a broad range of bearing types can be employed it is important to understand the bearing and seal types before proceeding. This information is critical in order to understand the optimal grease delivery points, grease flow paths, the requirements for efficient grease exchange and the point(s) of grease exit from bearing housings.

During the implementation of perma STAR VARIO it is important to address the following items:

- Ensure that the bearing housing is correctly packed with grease in order to ensure efficient grease exchange. This is especially important for bearing types which must be re-lubricated from the side, rather than via a central relubrication groove
- Where contact seals which are not free purging are in use, such as double lip seals, ensure that a suitable point for grease relief is introduced to the housing in order to avoid over-lubrication
- Consider the use of high performance greases which can withstand the high rate of mechanical work which is applied by high speed rolling element bearings such as spherical roller bearings

## Lubrication assessment criteria

For fan lubrication the following factors are generally assessed in order to develop the lubrication solution:

- Bearing types & speeds
- Seal types
- Grease entry points and grease migration directions
- Typical bearing operating temperatures
- Characteristics of proposed lubricant
- Historical lubrication practices
- Operating conditions
- Requirements for safe access
- Desired service schedule

## Installation examples



**Application** Fan support bearings  
**Lubricator** perma STAR VARIO 250 cm<sup>3</sup>  
**Installation kit** K230



**Application** Fan support bearings  
**Lubricator** perma STAR VARIO 120 cm<sup>3</sup>  
**Installation kit** Direct mount



**Application** Fan support bearings  
**Lubricator** perma STAR VARIO 250 cm<sup>3</sup>  
**Installation kit** K230

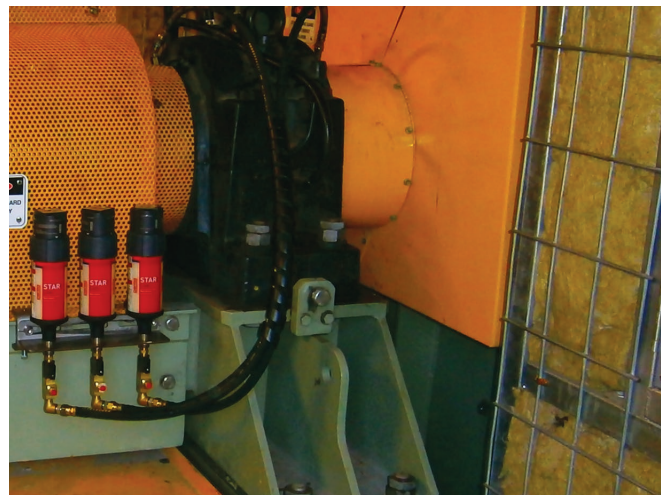

**Application** Fan support bearings  
**Lubricator** perma STAR VARIO 250 cm<sup>3</sup>  
**Installation kit** K330

# Accessories

The Correct Accessories for Your Mounting System



Minimising the pressure loss between single point lubricators and lubrication points is an important factor for achieving long term, reliable lubricant delivery. The range of accessories available from perma have been carefully selected to ensure that pressure losses are minimised and that installations will stand the test of time in harsh operating environments.

## Adaptors, elbows, extensions, grease lines & general fittings

perma lubricators have a 1/4" BSP male thread at the grease outlet. Where reducers, elbows or extension are required to facilitate installation it is important to adhere to the following guidelines:

- When using reducing adaptors down to fine threads such as 6mm metric or 1/4" UNF select stainless steel to avoid breakage
- Minimise the number of elbow fittings
- Always select full bore elbows

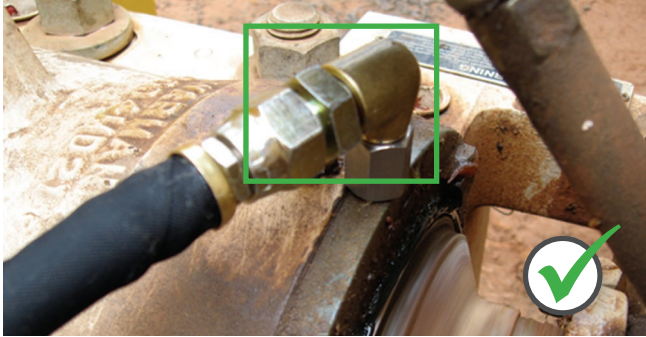

Part #	Description	Pic.	Part #	Description	Pic.
2461/8	Straight adaptor brass 1/4" BSPP F - 1/8" BSPT M	1	92JSS	Elbow stainless steel 90 degree 1/4" BSPT M - 9/16" JIC M	10
2461/4	Straight adaptor brass 1/4" BSPP F - 1/8" BSPT M	2	921/8JSS	Elbow stainless steel 90 degree 1/8" BSPT M - 9/16" JIC M	-
2461/4UNFSS	Straight adaptor stainless steel 1/4" BSPP F - 1/4" UNF M	3	92	Elbow brass 90 degree 1/4" BSPP F - 1/4" BSPT M	11
2466SS	Straight adaptor stainless steel 1/4" BSPP F - M6x1.0 M	4	1216SS	Elbow brass 45 degree 1/4" BSPP F - M6x1.0 M	12
2468	Straight adaptor brass 1/4" BSPP F - M8x1.0 M	5	1211/8	Elbow brass 45 degree 1/4" BSPP F - 1/8" BSPT M	-
2468SS	Straight adaptor stainless steel 1/4" BSPP F - M8x1.0M	6	1211/4	Elbow brass 45 degree 1/4" BSPP F - 1/4" BSPT M	13
24610	Straight adaptor brass 1/4" BSPP F - M10x1.0 M	7	52740	Extension brass 40mm 1/4" BSPP F - 1/4" BSPT M	14
24610SS	Straight adaptor stainless steel 1/4" BSPP F - M10x1.0M	8	5270501/8	Extension brass 50mm 1/4" BSPP F - 1/8" BSPT M	15
88HDJ	Hose end swivel 3/8" hose to 1/4" BSP M	9	52750M6SS	Extension stainless steel 50mm 1/4" BSPP F - M6x1.0 M	16
90HD	Hose baryon fibre reinforced internal diameter 3/8"	-	52785	Extension brass 85mm 1/4" BSPP F - 1/4" BSPT M	-
708V	Manual greasing kit 1/4" BSP	17	527125	Extension brass 125mm 1/4" BSPP F - 1/4" BSPT M	19
HDC250	Full length cover heavy duty for L250 STAR VARIO	18	A620P	Support flange 1/4" BSP	20

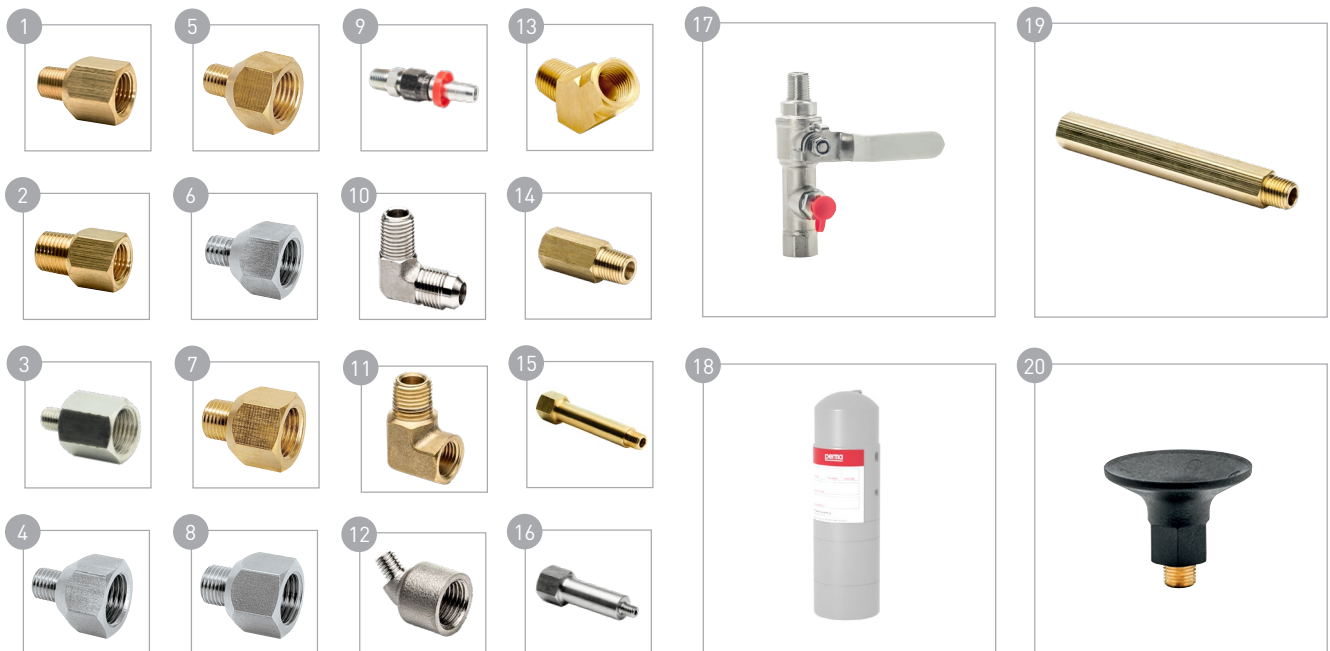

## Stainless steel brackets and attachment options

The range of stainless steel brackets and attachment options included in remote installation kits can be purchased as separate components. Brackets are available bare or complete with A620P support flanges. The A620P reinforces perma STAR VARIO lubricators to protect against accidental breakage. The table below includes bare brackets and brackets with A620P's. Note that Heavy Duty C-Section brackets always include A620P's and full length covers. With the exception of Heavy Duty brackets, only bare brackets are pictured below.

Part # (bare)	Description	Pic.	Part # (with A620P)	Compatible attachment options
BC30	Beam clamp 30mm	A	-	This is an attachment option
BC65	Beam clamp 65mm	B	-	This is an attachment option
CH-ARMS	Cage hanger twin arm set	C	-	This is an attachment option
MB01	Standard duty 1 point bracket	1	MB01A620P	Select from BC30 or BC65
MB02	Standard duty 2 points bracket	2	MB02A620P	Select from BC30 or BC65
MB03	Standard duty 3 points bracket	3	MB03A620P	Select from BC30 or BC65
MB04	Standard duty 4 points bracket	4	MB04A620P	Select from BC30 or BC65
-	Heavy duty C-section 1 point bracket	5	MB01C	Select from BC30 or BC65 or CH-ARMS
-	Heavy duty C-section 2 points bracket	6	MB02C	Select from BC30 or BC65 or CH-ARMS
-	Heavy duty C-section 3 points bracket	7	MB03C	Select from BC30 or BC65 or CH-ARMS
-	Heavy duty C-section 4 points bracket	8	MB04C	Select from BC30 or BC65 or CH-ARMS
CH01	Cage hanger 1 point bracket	9	CH01A620P	Cage hooks supplied with bracket
CH02	Cage hanger 2 points bracket	10	CH02A620P	Cage hooks supplied with bracket
CH03	Cage hanger 3 points bracket	11	CH03A620P	Cage hooks supplied with bracket
CH04	Cage hanger 4 points bracket	12	CH04A620P	Cage hooks supplied with bracket
MB01R	Rail mount 1 point bracket	13	MB01RA620P	U-bolts supplied with bracket
MB02R	Rail mount 2 points bracket	14	MB02RA620P	U-bolts supplied with bracket
MB03R	Rail mount 3 points bracket	15	MB03RA620P	U-bolts supplied with bracket
MB04R	Rail mount 4 points bracket	16	MB04RA620P	U-bolts supplied with bracket

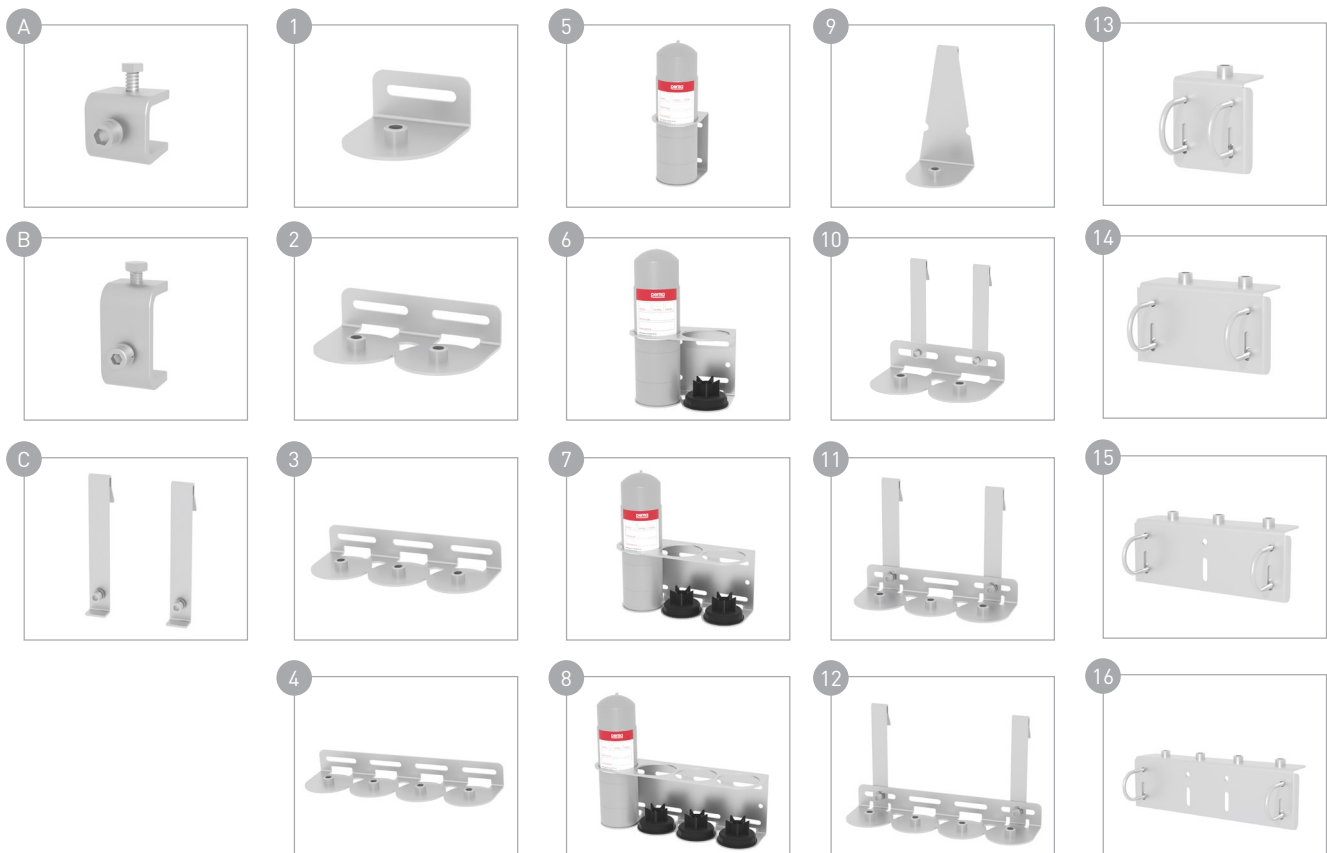

## Pre-assembled and pre-filled lubricator grease lines

Pre-assembled, pre-filled grease lines are supplied ready to use. They save time, ensure against the accidental inclusion of contaminants when making grease lines on site and remove the need for laborious manual filling. The range of grease lines from perma come in pre-set lengths.

- 3/8" internal diameter with single, synthetic fibre braid.
- Full bore female swivel, push-lock fittings at each end of hose for convenient fitting with adaptors to 1/4" BSP male
- Minimum burst pressure = 84 bar
- Complies with FRAS AS2660
- Minimum bend radius 76 mm

Line Length	0.5m	0.75m	1.0m	1.5m	2.0m	2.5m	3.0m
Generic Part #	PSFXXX90HD0.5	PSFXXX90HD.75	PSFXXX90HD1.0	PSFXXX90HD1.5	PSFXXX90HD2.0	PSFXXX90HD2.5	PSFXXX90HD3.0

The table above provides generic part numbers for different length hose assemblies. The first 6 digits of each part number identifies the grease type. Specific part numbers for preferred grease types are created by replacing the first six digits of the generic part number with the relevant perma lubricant code.

**For example, a pre-assembled grease line with a length of 1.5 meters which is filled with Castrol Spheerol LX EP2 grease:**

- Generic part number for 1.5 meter line is PSFXXX90HD1.5
- 6 digit reference code for Castrol Spheerol LX EP2 grease is PSF826
- Hence, part number for required line is PSF82690HD1.5

## Chain lubrication accessories

Part #	Description	Pic.	Part #	Description	Pic.
A400	Brush 20cm round 1/4 " BSP for oil	1	A810	Throttle one-way valve 1/4 " BSP for oil	5
A410	Brush 3 x 4cm rectangular 1/4 " BSP for oil	2	A100	Metal bracket standard duty	6
A411	Brush 3 x 6cm rectangular 1/4 " BSP for oil	3	A105	Universal plastic bracket	7
A412	Brush 3 x 10cm rectangular 1/4 " BSP for oil	4	A150	T-piece bracket with 1/4 " BSP insert	8

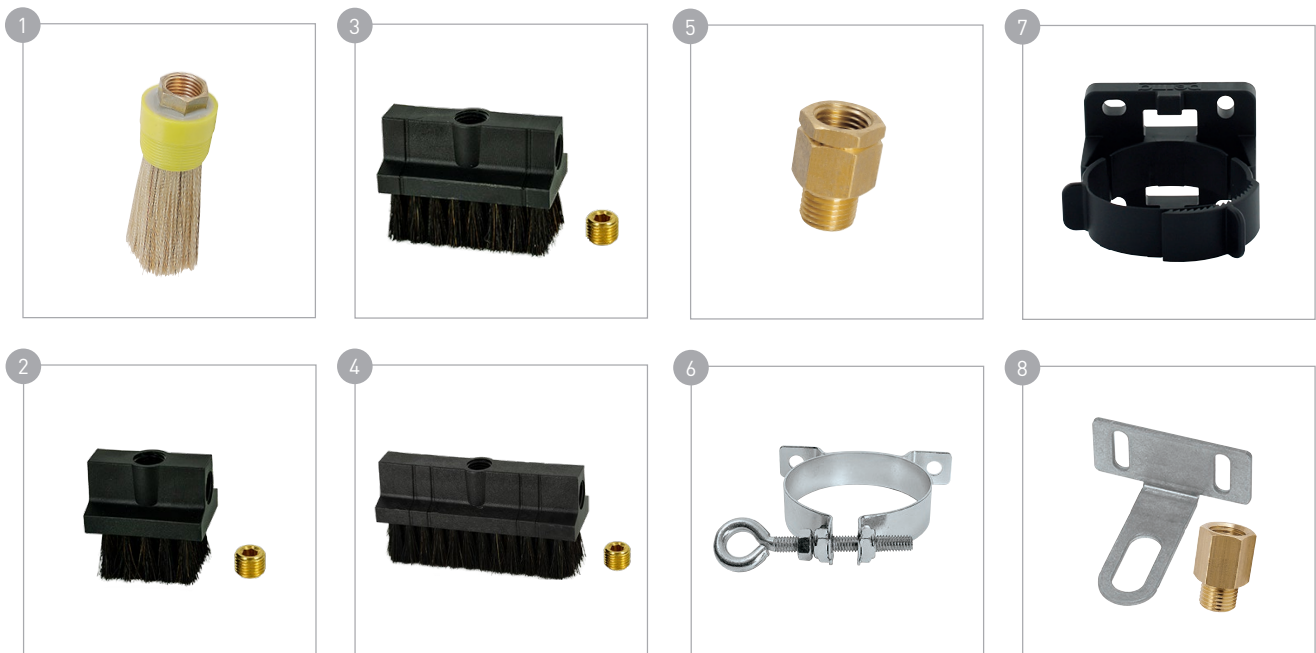

# Fittings Cases

## Part Numbers and Case Contents



Various fittings cases are available to provide a convenient and economical option for on-site spares. The themed cases include carefully selected reducing adaptors, extensions and elbows. The cases have a heavy duty plastic construction with an integrated water seal, removable compartments, impact resistant lid and heavy duty latches. These tables list the parts included in each fittings case option. If different combinations are required, please contact your supply of perma products to investigate the supply of a customised option.

**FCGEN220 - Contains the most commonly used fittings for perma STAR VARIO**

Stock code	Qty	Description
<b>A620P</b>	20	Support flange suits STAR 1/4" BSPT M
<b>708V</b>	10	Manual greasing kit 1/4" BSPT M
<b>88HDJ</b>	20	Hose end swivel 3/8" hose - 9/16" JIC F and 9/16" JIC M - 1/4" BSPT M straight adaptor
<b>92</b>	20	Elbow brass 90 degree 1/4" BSPP F - 1/4" BSPT M
<b>1211/4</b>	20	Elbow brass 45 degree 1/4" BSPP F - 1/4" BSPT M
<b>2461/8</b>	30	Adaptor straight brass 1/4" BSPP F - 1/8" BSPT M
<b>527501/8</b>	20	Extension brass 50mm 1/4" BSPP F - 1/8" BSPT M
<b>52750M6SS</b>	20	Extension stainless steel 50mm 1/4" BSPP F - M6 x 1.0 M
<b>2466SS</b>	30	Adaptor straight stainless steel 1/4" BSPP F - M6 x 1.0 M
<b>2461/4UNFSS</b>	30	Adaptor straight stainless steel 1/4" BSPP F - 1/4" UNF M

**FCBSP240 - Contains primarily brass BSP fittings plus stainless reducers to M6 x 1.0 and 1/4" UNF M**

Stock code	Qty	Description
<b>2461/4</b>	30	Adaptor straight brass 1/4 " BSPP F - 1/4 " BSPT M
<b>2461/8</b>	30	Adaptor straight brass 1/4 " BSPP F - 1/8 " BSPT M
<b>92</b>	40	Elbow brass 90 degree 1/4 " BSPP F - 1/4 " BSPT M
<b>1211/4</b>	40	Elbow brass 45 degree 1/4 " BSPP F - 1/4 " BSPT M
<b>1211/8</b>	20	Elbow brass 45 degree 1/4 " BSPP F - 1/8 " BSPT M
<b>527501/8</b>	15	Extension brass 50mm 1/4 " BSPP F - 1/8 " BSPT M
<b>52740</b>	15	Extension brass 40mm 1/4 " BSPP F - 1/4 " BSPT M
<b>52750M6SS</b>	10	Extension stainless steel 50mm 1/4 " BSPP F - M6x1.0 M
<b>2466SS</b>	20	Adaptor straight stainless steel 1/4 " BSPP F - M6x1.0 M
<b>2461/4UNFSS</b>	20	Adaptor straight stainless steel 1/4 " BSPP F - 1/4" UNF M

**FCJICHOSE145 - Contains a range of JIC hose connection fittings and various adaptors and extensions**

Stock code	Qty	Description
<b>88HDJ</b>	20	Hose end swivel 3/8" hose - 9/16" JIC F and 9/16" JIC M - 1/4" BSPT M straight adaptor
<b>92JSS</b>	20	Elbow 90 degree 9/16" JIC M - 1/4" BSPT M
<b>92J1/8SS</b>	20	Elbow 90 degree 9/16" JIC M - 1/8" BSPT M
<b>2807/16M</b>	10	Adaptor 7/16" JIC M to 9/16" JIC M
<b>2807/16F</b>	10	Adaptor 7/16" JIC F to 9/16" JIC M
<b>52740</b>	15	Extension brass 40mm 1/4 " BSPP F - 1/4 " BSPT M
<b>708V</b>	5	Manual greasing kit 1/4" BSPT M
<b>527501/8</b>	10	Extension brass 50mm 1/4" BSPP F - 1/8" BSPT M
<b>52750M6SS</b>	15	Extension stainless steel 50mm 1/4" BSPP F - M6x1.0 M
<b>2461/8SS</b>	20	Adaptor straight stainless steel 1/4 " BSPP F - 1/8" BSPT M

## Part numbers and case contents

### FCMETRIC230 - Contains adaptors from metric to 1/4" BSPP F plus BSP elbows and reducers

Stock code	Qty	Description
2466SS	30	Adaptor straight stainless steel 1/4" BSPP F – M6 x 1.0 M
1216SS	20	Elbow stainless steel 45 degree 1/4" BSPP F – M6 x 1.0 M
52750M6SS	15	Extension stainless steel 50 mm 1/4" BSPP F – M6 x 1.0 M
2468	25	Adaptor straight brass 1/4" BSPP F – M8 x 1.0 M
2468X1.25	20	Adaptor straight brass 1/4" BSPP F – M8 x 1.25 M
24610	20	Adaptor straight brass 1/4" BSPP F – M10 x 1.0 M
24610X1.25	20	Adaptor straight brass 1/4" BSPP F – M10 x 1.25 M
24610X1.5	20	Adaptor straight brass 1/4" BSPP F – M10 x 1.5 M
52740	20	Extension brass 40 mm 1/4" BSPP F – 1/4" BSPT M
92	40	Elbow brass 90 degree 1/4" BSPP F – 1/4" BSPT M

### FCSBSP130 - Contains a range of brass BSP fittings

Stock code	Qty	Description
2461/4	30	Adaptor straight brass 1/4" BSPP F – 1/4" BSPT M
2461/8	30	Adaptor straight brass 1/4" BSPP F – 1/8" BSPT M
92	20	Elbow brass 90 degree 1/4" BSPP F – 1/4" BSPT M
1211/4	20	Elbow brass 45 degree 1/4" BSPP F – 1/4" BSPT M
52740	20	Extension brass 40 mm 1/4" BSPP F – 1/4" BSPT M
52785	10	Extension brass 85 mm 1/4" BSPP F – 1/4" BSPT M

### FCSCOMB0160 - Contains a range of brass BSP and metric fittings

Stock code	Qty	Description
2461/4	30	Adaptor straight brass 1/4" BSPP F – 1/4" BSPT M
2461/8	30	Adaptor straight brass 1/4" BSPP F – 1/8" BSPT M
92	20	Elbow brass 90 degree 1/4" BSPP F – 1/4" BSPT M
1211/4	20	Elbow brass 45 degree 1/4" BSPP F – 1/4" BSPT M
2468	20	Adaptor straight brass 1/4" BSPP F – M8 x 1.0 M
24610	20	Adaptor straight brass 1/4" BSPP F – M10 x 1.0 M
52740	20	Extension brass 40 mm 1/4" BSPP F – 1/4" BSPT M

**FCSJICHOSESS110 - Contains a range of 316SS JIC hose connection fittings and straight adaptors**

Stock code	Qty	Description
88JSS	20	Hose end stainless steel 3/8" hose - 9/16" JIC F swivel
280JSS	20	Nipple stainless steel 1/4" BSPT M - 9/16" JIC M
92JSS	20	Elbow 90 degree 9/16" JIC M - 1/4" BSPT M
92J1/8SS	20	Elbow 90 degree 9/16" JIC M - 1/8" BSPT M
52750M6SS	10	Extension stainless steel 50 mm 1/4" BSPP F - M6 x 1.0 M
2461/8SS	20	Adaptor straight stainless steel 1/4" BSPP F - 1/8" BSPT M

**FCSS250 - Contains a range of stainless steel fittings**

Stock code	Qty	Description
2466SS	20	Adaptor straight stainless steel 1/4" BSPP F - M6 x 1.0 M
1216SS	20	Elbow stainless steel 45 degree 1/4" BSPP F - M6 x 1.0 M
52750M6SS	10	Extension stainless steel 50 mm 1/4" BSPP F - M6 x 1.0 M
2468SS	20	Adaptor straight stainless steel 1/4" BSPP F - M8 x 1.0 M
24610SS	20	Adaptor straight stainless steel 1/4" BSPP F - M10 x 1.0 M
2461/4UNFSS	30	Adaptor straight stainless steel 1/4" BSPP F - 1/4" UNF M
2461/8SS	20	Adaptor straight stainless steel 1/4" BSPP F - 1/8" BSPT M
48SS	30	Grease nipple stainless steel 1/4" BSPT M
280SS	40	Nipple stainless steel 1/4" BSPT M - 1/4" BSPT M
26SS	40	Socket round stainless steel 1/4" BSP

More information about these fittings cases can be found on our website [www.perma.com](http://www.perma.com)



# Inspection Guidelines

The periodic inspection of lubricators is important to support the integrity of the overall lubrication

The following points are important:

- Inspection of lubricators should be carried out by a competent person who understands the various display and light sequence combinations.
- A permanent marker should be carried in order to mark and date the piston positions.

**A**

Remove lubricator cover. Leave the lubricator in its mounted position to complete the inspection.



**B**

Confirm status using the display screen / flashing lights. The time setting on the display and a green light indicates normal operation.



**C**

Check, mark and date the position of the piston. Compare the position to the expected piston position.



**D**

Refit lubricator cover.



**E**

Check the condition of fittings and grease lines. Repair or raise work orders as required.



# Service Guidelines

The service procedure for the perma STAR VARIO is summarised here

## Important notes to include:

- ALWAYS exchange battery set;
- ALWAYS record service dates on canister;
- Lubricators can be serviced without removing the clear wet cap;
- Replacing the battery set automatically resets the lubricator so there is no need to turn lubricators OFF and then ON again when servicing.

**A**

Confirm lubricator status via display screen & piston level.



**B**

Do not turn the lubricator off. Remove lubricator, disassemble & remove battery set using eject trigger.



**C**

Exchange lubricant canister and battery set.



**D**

Insert new battery set, attach new canister and re-assemble. An automatic self test will occur.



**E**

Lubricator will start automatically. Observe first run cycle and afterwards confirm that the setting is correct



**F**

Record installation and next service dates on canister and remount to lubrication point.



# perma LUBRICANTS

The Correct Lubricant for a Longer Service



## Custom fill lubricants

HTL perma Australia Pty Ltd is equipped with lubricator filling machines from Germany and has the capability to custom fill lubricators with any suitable grease or oil.

The demand for custom filled lubricants is increasing. Typical reasons for choosing custom filled lubricants are:

- Where lubricant rationalisation programs have been implemented and it is preferred that the lubricants in automatic lubricators conform to the rationalisation decisions
- Where certain applications demand specialty lubricants
- Where the mixing of different lubricants presents a real risk of incompatibility problems
- Where specific lubricants are required in order to satisfy warranty requirements
- Where specific lubricant brands must be used in order to adhere to contractual obligations

→ perma code → Name	NLGI class	Thickener	Base oil	Operating temperature (°C)	Viscosity at +40°C	Roller bearings	Sliding bearings Guides	Linear guides	Open gears Gear racks	Spindles	Shaft seals (1)	Chains
<b>GREASE</b>												
<b>SF01</b> perma MULTI LC 220-2 grease	2	Li / Ca	Mineral oil	-30 to +130	220	✓	✓	✓	-	✓	✓	-
<b>PSF721</b> perma MULTI BLUE LC 220 grease	2	Li / Ca	Mineral oil	-30 to +130	220	✓	✓	✓	-	✓	✓	-
<b>SF02</b> perma LOAD L-M 100-2 grease	2	Li + MoS2	Mineral oil	-30 to +120	100	-	✓	-	✓	-	-	-
<b>SF04</b> perma PU SYN 500-1 grease	1	Poly	Mineral oil + PAO	-20 to +160	500	✓	✓	✓	✓	-	-	-
<b>SF05</b> perma PU-M SYN 500-1 grease	1	Poly + MoS2	Mineral oil + PAO	-20 to +160	500	✓	✓	✓	✓	-	-	-
<b>SF10</b> perma FOOD AX SYN 150-1 grease	1	Al Com.	Synthetic	-45 to +120	150	✓	✓	✓	✓	-	-	-
<b>OIL</b>												
<b>S014</b> perma TEMP SYN 320 oil	Oil	-	Synthetic	-20 to +250	320	-	-	-	-	-	-	✓
<b>S032</b> perma MULTI 100 oil	Oil	-	Mineral oil	-5 to +100	100	-	✓	-	✓	✓	-	✓
<b>S070</b> perma FOOD SYN 220 oil	Oil	-	Synthetic	-30 to +120	220	-	✓	-	✓	✓	-	✓

## Grease pumpability

The pumpability of grease depends on a range of factors, the most influential being the grease type, temperature and the internal dimensions of delivery lines and fittings.

**Grease type** - The lower the NLGI rating the easier grease is to pump. NLGI 2 greases are easier to pump than NLGI 3 greases and so on. Grease thickener type, base fluid viscosity and manufacturing methods also have an effect on grease pumpability.

**Temperature** - Grease is easier to pump in warmer environments than in cold environments. However, the relationship between pumpability and temperature is not linear, so as temperature drops it is difficult to predict the point at which grease will become substantially more difficult to pump.

**Grease line dimensions and fittings** - The nature of grease flow through lines and fittings is different to that of liquid lubricants such that pressure drops cannot be calculated on the basis of "pipe friction loss" style calculations. In general it is best to minimise grease line length, use generous sized grease line (perma recommends 3/8" ID) and eliminate restrictive elbow fittings.



# Notes





**HTL perma Australia Pty Ltd**

150 Highbury Road  
Burwood, VIC 3125  
AUSTRALIA

+61 3 9273 7700  
technical@perma.com.au  
www.perma.com.au